

Radial Shaft Seal Technical Manual

simrit[®]

Contents

Introduction	i		
Seal Nomenclature	ii		
Seal Selection Process	iii		
Simrit Seal Profiles	iv		
General	1.0	Contamination – General	6.0
Dynamic Sealing Behavior	1.1	Contamination Excluder Designs	6.10
System Durability-General	2.0	Installation – General	7.0
Areas of Influence	2.1	Installation Procedures – Standard	7.1
Frictional Life	2.1.1	Installation over Splines	7.1.1
System Temperature	2.1.2	Installation – Heavy Duty	7.1.2
Lubrication Factors	2.1.3	Installation – Long Shaft	7.1.3
Speed Limitations	2.1.4		
Eccentricity - General	3.0	Leakage – General	8.0
Eccentricity Limits	3.1	Causes of Failure	8.1
Run-out and Offset	3.2	Warranty Avoidance Checklist	8.2
Seal Design – General	4.0	Defect Sources & Remedial	
Pressure Seals	4.1	Measures	9.0
Pressure Limits	4.2	 	
Pressure Seal Capabilities	4.3	Material – General	10.0
O.D. Sealing & Design	4.4	Media to be Sealed	10.1
O.D. Types	4.5	Material Selection	10.2
O.D. Sealing	4.6	Temperature Ranges	10.2.1
O.D. Sealing Summary	4.6.1	Hardness Changes	10.2.2
		Volume Change	10.2.3
		Durability	10.2.4
		Retraction Results	10.2.5
		Material Properties	10.3
Surface Finish – General	5.0	Simrit Lip Style Designations ...	11.0
Structure of the Shaft	5.1	 	
Conditions	5.2	Glossary of Terms	12.0
Plunge Grinding	5.3	 	
Housings	5.4	Conversion Charts	13.0
Bore Material & Finish	5.5		
Housing Recommendations	5.6		

Introduction:

The data in this technical catalog is based on experience gained by Simrit through the Freudenberg & NOK Group Companies. Decades of research have been conducted into both the development and manufacture of our Simrit Radial Shaft Seals. Nevertheless, the information in this catalog may be significantly modified as a result of factors occurring during practical use of our product, which may be unknown to the company. Therefore, the data contained herein, can only be considered general, non-binding, approximate values. For this reason we strongly encourage you to contact your Simrit representative to discuss specific applications.

The data in this catalog may be altered without prior notice.

This publication may only be reproduced with the express consent of Simrit:

Simrit
47690 East Anchor Court
Plymouth, MI 48170-2455
Phone: 734-451-0020
Attention: Simrit Marketing Department

This publication supercedes and renders all previous Radial Shaft Seal Technical Data invalid.

Seal Nomenclature

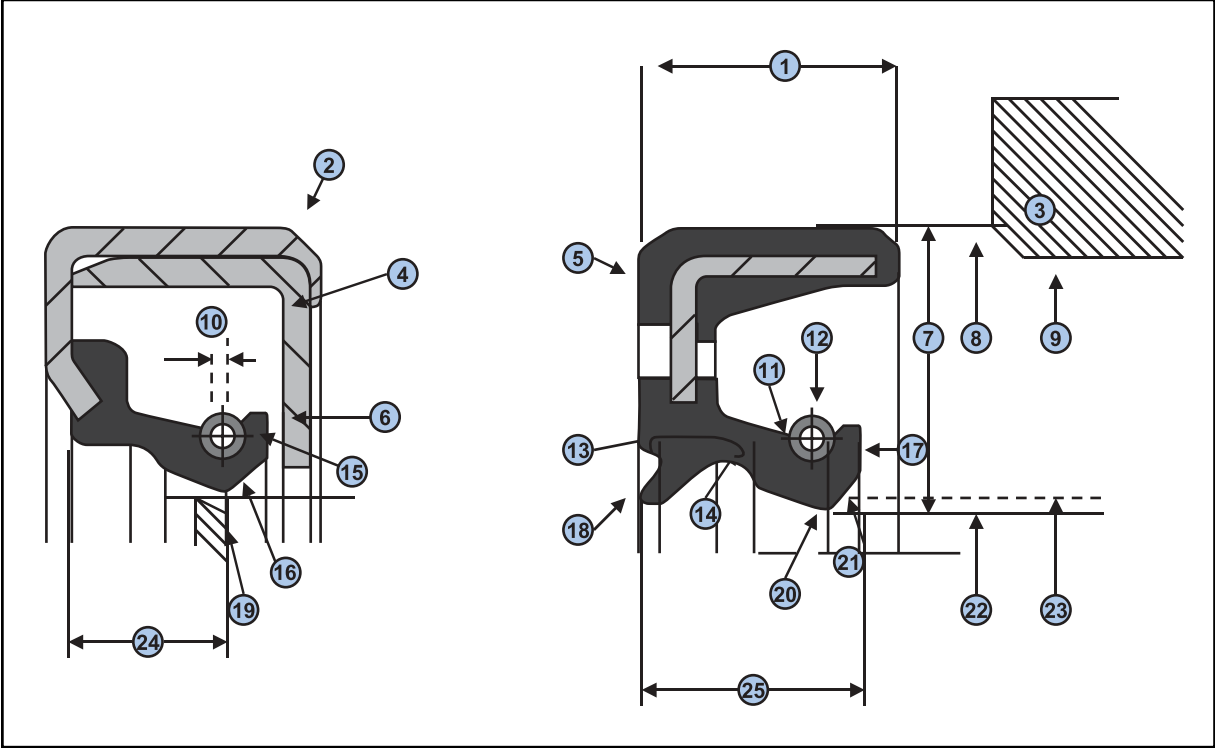







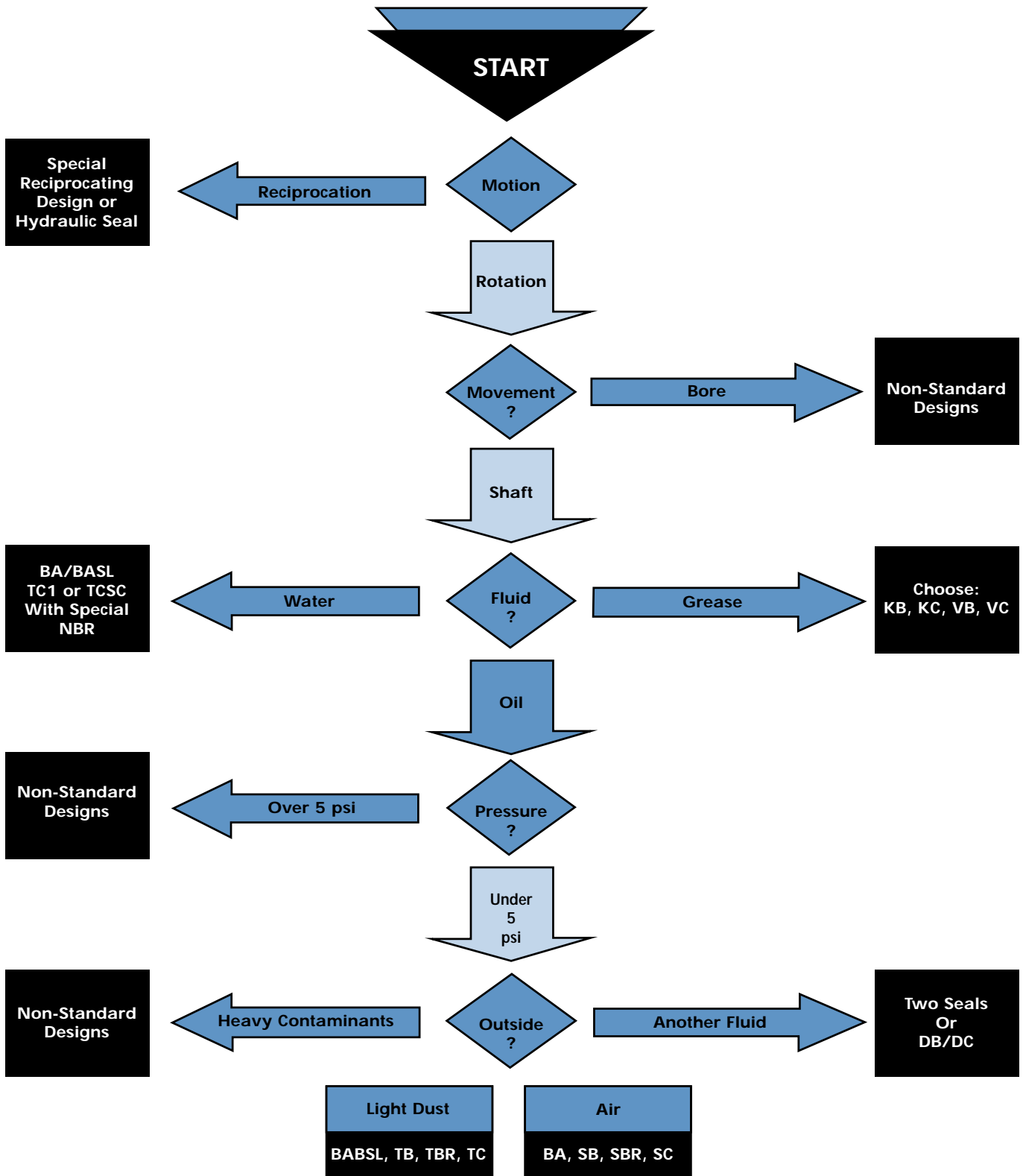



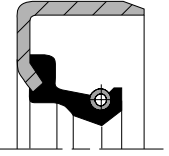
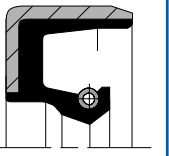

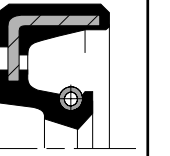

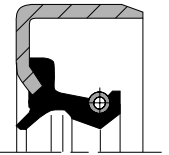
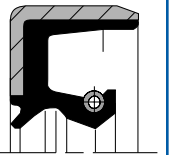
- 1. Seal Width
- 2. Metal Case (Outer)
- 3. Housing
- 4. Inner Case
- 5. Outside Face
- 6. Inside Face
- 7. Radial Wall
- 8. Seal Outer Diameter
- 9. Housing Bore Diameter
- 10. Spring Position (R-Value)
- 11. Spring Groove
- 12. Garter Spring
- 13. Heel Section
- 14. Flex Section
- 15. Spring Retainer Lip
- 16. Inside Lip Angle
- 17. Toe Face
- 18. Auxiliary (Dust) Lip
- 19. Rib (Helix)
- 20. Contact Point
- 21. Inside Lip Surface
- 22. Spring Set Lip Diameter
- 23. Free Lip (Unsprung) Diameter
- 24. Contact Line Height
- 25. Lip Height

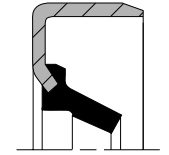
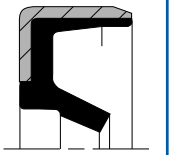

Seal Selection Process

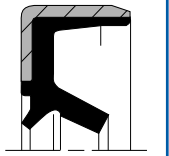
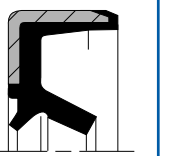
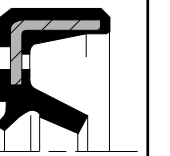

Simrit Seal Profiles

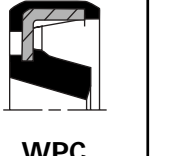
LIP SYMBOLS		BODY SYMBOLS				
		Metal O.D. design with an inner case for greater structural rigidity	Most standard and economic design	Metal O.D. design with rubber covering on fluid side	Old Design O.D. part metal/ part rubber	Rubber O.D. design for excellent sealability
S	General non-pressure sealing applications and severe grease sealing conditions	 SA2 <small>*B2</small>	 SB2 <small>*B1</small>	 SB <small>*B1</small>	 SBR	 SC <small>*BA</small>
		 TA2 <small>*B2 SL</small>	 TB2 <small>*B1 SL</small>	 TB <small>*B1 SL</small>	 TBR	 TB <small>*BA SL</small>
		 VA2	 VB2	 VB	 VBR	 VC
		 KA2	 KB2	 KB	 KBR	 KC
		 WPB				 WPC

Note: Metal O.D. seals are most suitable for steel or cast iron housings. Rubber O.D. seals are preferred for soft alloy or plastic housing materials and are also suitable for steel or cast iron housings. In addition, this design category is best for rough bore finishes or for materials with a high coefficient of thermal expansion.

*Simrit Europe design equivalent



General

Mechanics of a Radial Shaft Seal - General

A Simrit Radial Shaft Seal is used to seal a rotating shaft against the predominantly stationary housing of the unit. The most important functioning area of the radial shaft seal is the sealing edge which comes in contact with the surface area of a rotating shaft.

(See figure 1, pg 1.1)

The sealing mechanism in the sealing lip is critically important when it comes to the sealing function. It is dependent on:

- The layout of the sealing lip
- The properties of the elastomeric material
- The finish of the shaft surface

Characteristic dimensions of sealing lip profile

A good knowledge base in seal design and function is required prior to establishing and interpreting characteristic dimensions.

Dimensions are set by each manufacturer depending on the material properties, size and lip geometry.

hD and S_m are set depending on the shaft diameter and the operating conditions. The coordination of both of these dimensions affects the flexibility of the lip:

- Long and flexible sealing lips for high tolerances of offset (static eccentricity) and concentricity

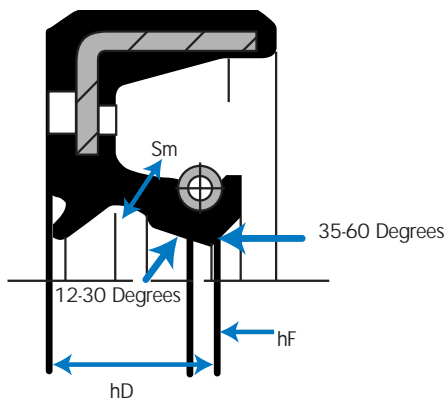

- For pressurized applications, a short profile and a stable profile for the shaft

The characteristic dimension for the distance from the center of the spring to the sealing edge is the spring plane (R-Value):

- An R-Value dimension that is too small can result in the toppling over of the seal, especially with any radial shaft deflection.
- Too large an hF dimension can cause the profile to tilt. This will cause a wide contact area on the shaft and result in a wide wear track.

Sealing lip geometry

The angle of the sealing lip influences the sealing mechanism by affecting conditions for contact pressure:

- Oiled side: steep angle 35 – 60 degrees
- Air side: shallow angle 12 – 30 degrees

The sealing lip inner diameter in a free state, is always smaller than the shaft diameter. The covering (also pre-tension) is the difference between these two measurements.

The dimension for the length of the lip is the measurement hD .

Dimension for the cross-section of the lip is S_m .

The characteristic dimension for the distance from the center of the spring to the sealing edge is the spring plane, hF .

Dynamic sealing behavior

The most important functional area of the Simrit Radial Shaft seal is the sealing edge which is in contact with the surface area of a rotating shaft. The sealing mechanism in the sealing lip contact area has the greatest impact on the performance of the seal and its function.

This is dependent on the layout of the sealing lip, the properties of the elastomeric material and the shaft surface finish.

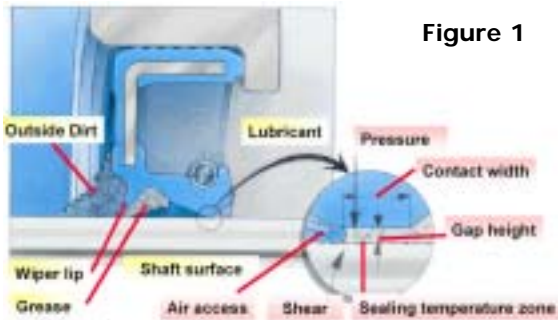

Figure 1

The radial force of the sealing lip, in combination with the geometry of the sealing lip angle and spring plane distance produces an asymmetric footprint representing the pressure contact points. (Figure 2)

- maximum pressure and steep increase on the oil side
- shallow decline on the air side

This is of significant importance as it relates to sealing function.

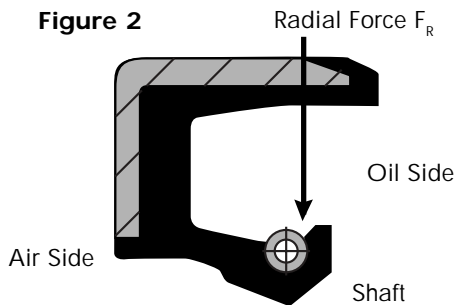

Figure 2

The contact pressure distribution by the asymmetric footprint and the power generated by the rotating shaft lead to a predictable characteristic deformation of the sealing lip. This predictable performance requires a good elastomeric material which provides a clear

structure of the sealing lips distortion features. (Figure 3)

This "distortion" occurs during the running-in phase of the seal. Therefore this run-in phase is critical to the seals performance. It creates a helix-effect and in combination with the shafts rotation, a pumping action directed at the oil side of the unit due to the predictable lip deformation.

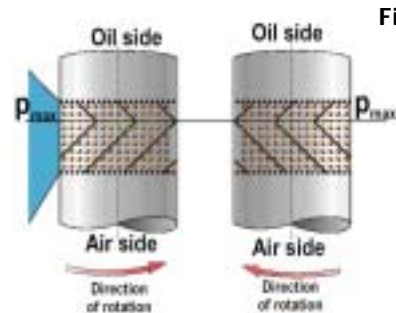

Figure 3

Even when stationary, the medium and lubrication used in sealing, penetrates the lip by capillary action on the uneven areas of the shaft. However, there is still direct contact of sealing lip with the shaft.

Should the complex relationships between the sealing lip and contact area be disrupted by: (Figure 4)

- improper shaft surface finish
- scratches, pores and other imperfections on the shaft and seal,
- contamination or corrosive products in the medium,
- hardening and cracks on the sealing edge, the seal will not perform properly and will be prone to leak.

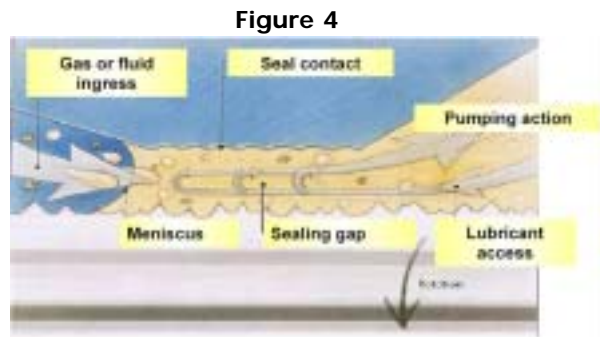

Figure 4

simrit[®]

Operating Variables

Radial Shaft Seals

STRIKING A DELICATE BALANCE

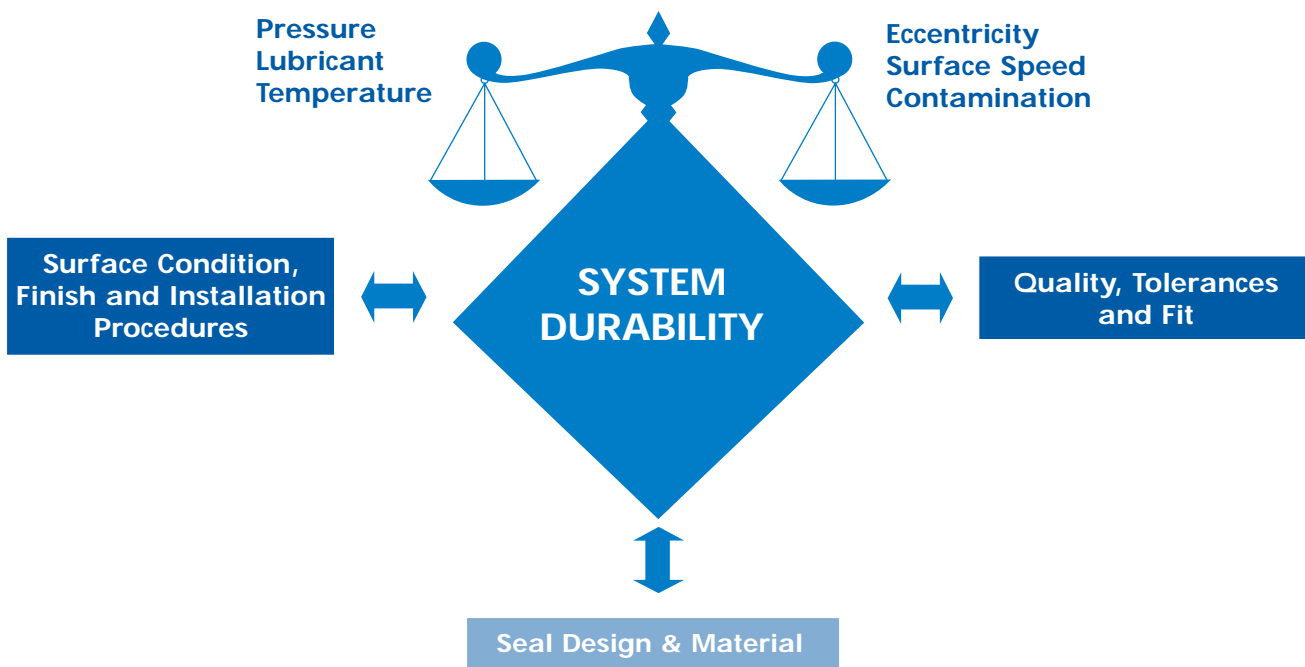

In order to reliably seal a rotating shaft, seal design must be carefully balanced with the operating conditions to maximize durability.

Areas of Influence

Speed

To determine the shaft's surface speed "V" the following formula applies:

$$\frac{\text{Shaft diameter } D \times \text{Revolutions per min } \times \pi}{V(\text{m/s}) = 60}$$

Temperature

The temperature on the sealing edge is higher than in the oil bath due to the rotation of the shaft and the corresponding friction produced.

Lubrication

An increase in the revolutions per minute, and consequently surface speed, equates to higher heat. Good lubrication and diffusion of the heat are important factors to ensuring the sealing edge falls within a permissible temperature range. Neglect in these areas leads to:

- High wear
- Premature hardening of the sealing lip
- Shortened seal life

Pressure

Simrit Radial Shaft Seals can be designed to handle pressures up to 150 psi. Most common seals, such as those shown on page iv, are designed for little or no internal fluid pressure.

Sealing against contaminants

The use of a Simrit Radial Shaft seal with a dust lip is recommended for sealing against the dirt, dust and moisture on the air side.

NOTE: Before installation, fill the space between sealing lip and dust lip with grease to +/- 40% of available space to ensure lubrication of the dust lip and to avoid any corrosion on the shaft. We would like to recommend grease from Kluber Lubrication.

In order to combat an aggressive attack from contaminants, it is possible to use two seals in tandem. For extreme conditions, standard combinations, labyrinth seals and modular sealing systems can be used. Please contact your Simrit representative for assistance.

Influence of Speed, Temperature & Lubricant

Radial Shaft Seals

STRIKING A DELICATE BALANCE

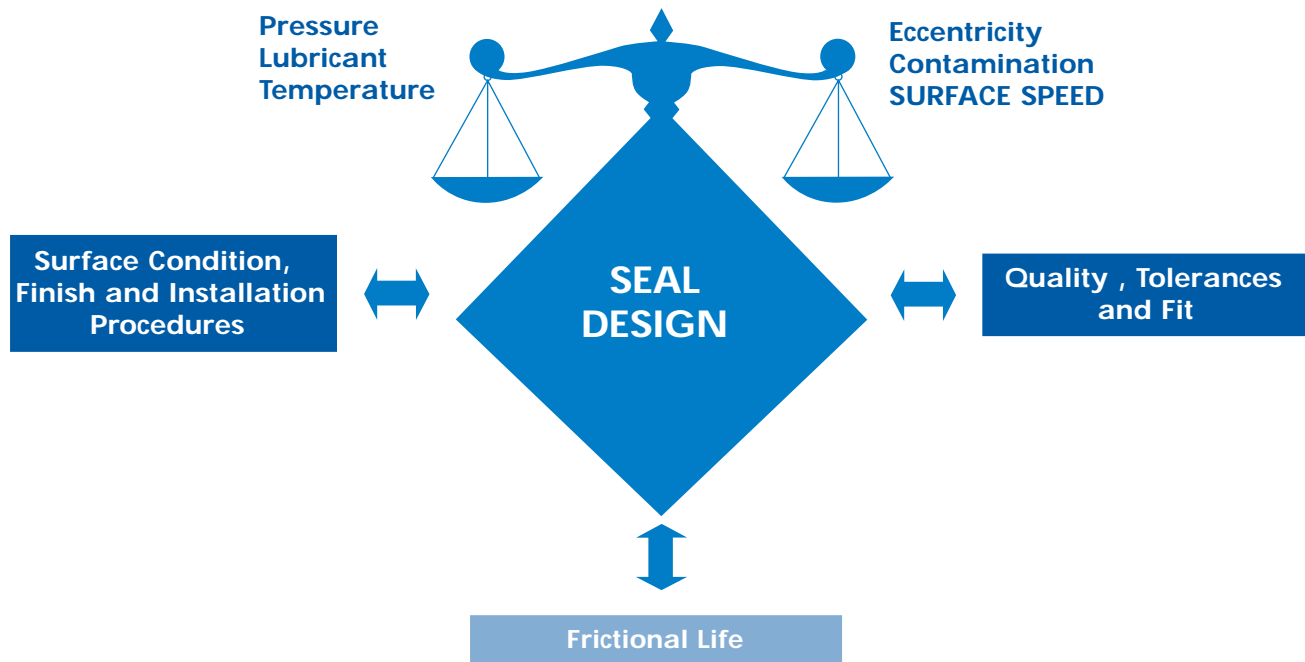

As shown above, the choice of lubricants, the environmental temperature, and the application speed are intimately related to the seal's frictional life.

Careful analysis of these variables and their relationship to the choice in seal design and materials allows the user to achieve desired durability goals with the most cost effective solution.

System Temperature

A seal will generate heat in excess of the oil sump temperature. The graph below shows the approximate amount of heat generated.

GENERAL SEAL LIP TEMPERATURE RISE ABOVE THE OIL SUMP TEMPERATURE

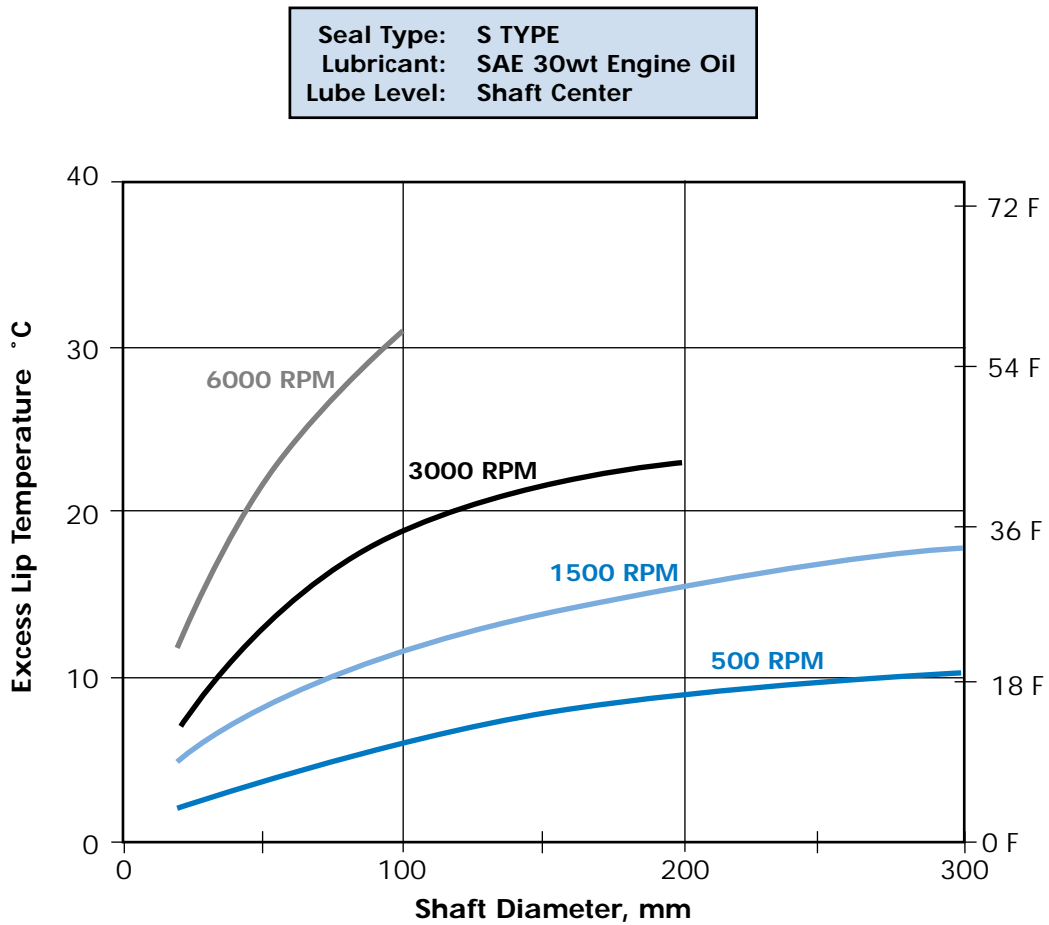

In order to determine the maximum temperature limitations of any particular material, you must look carefully at the operating conditions. First, determine the excess lip temperature generated in the application. Then, add to that the oil sump temperature. This is the upper temperature limit requirement to consider when choosing the seal material (see material section).



Lubrication Factors

The primary factors influencing the durability of a seal are the temperature, fluid, and the seal material.

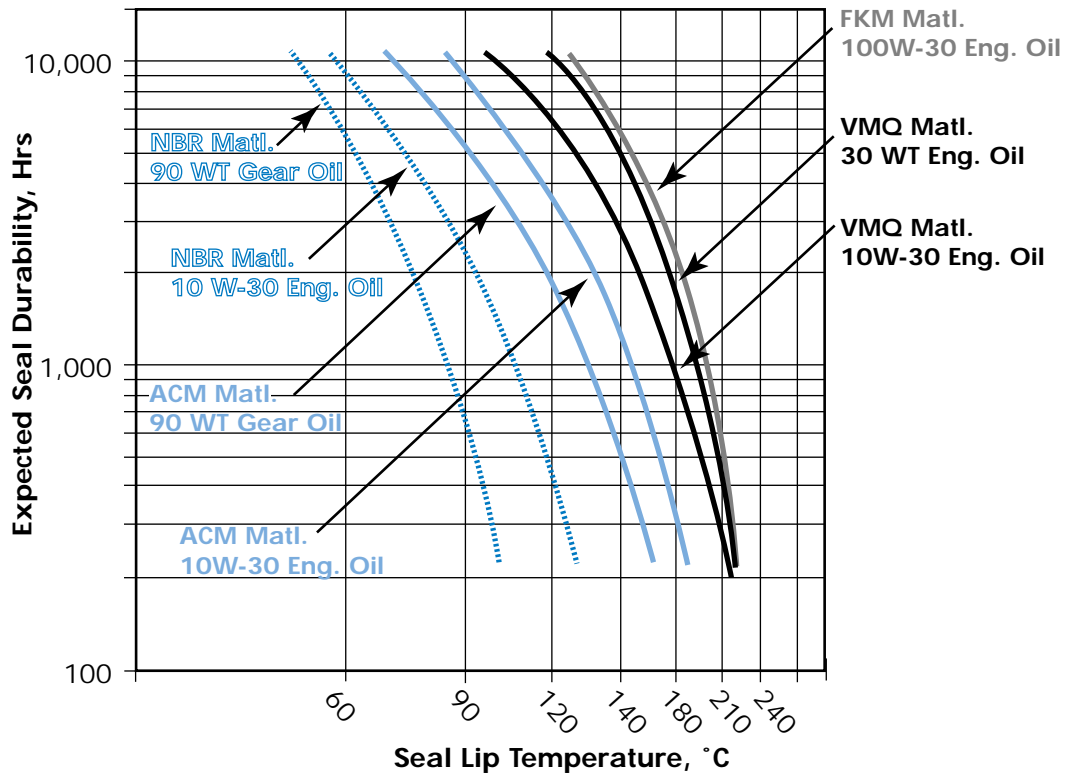

NBR = Nitrile
ACM = Polyacrylate
VMQ = Silicone
FKM = Fluoroelastomer

Using a lubricant that promotes seal durability can significantly increase seal life. In general, using a fluid that has good lubricity is desired. Additive packages that prevent oil breakdown at higher temperatures can attack a seal material, and should be reviewed with the Simrit representative. With the proper choice of fluid, seal design, and materials, seals can often last over 10,000 hours in clean environments.

Speed Limitations

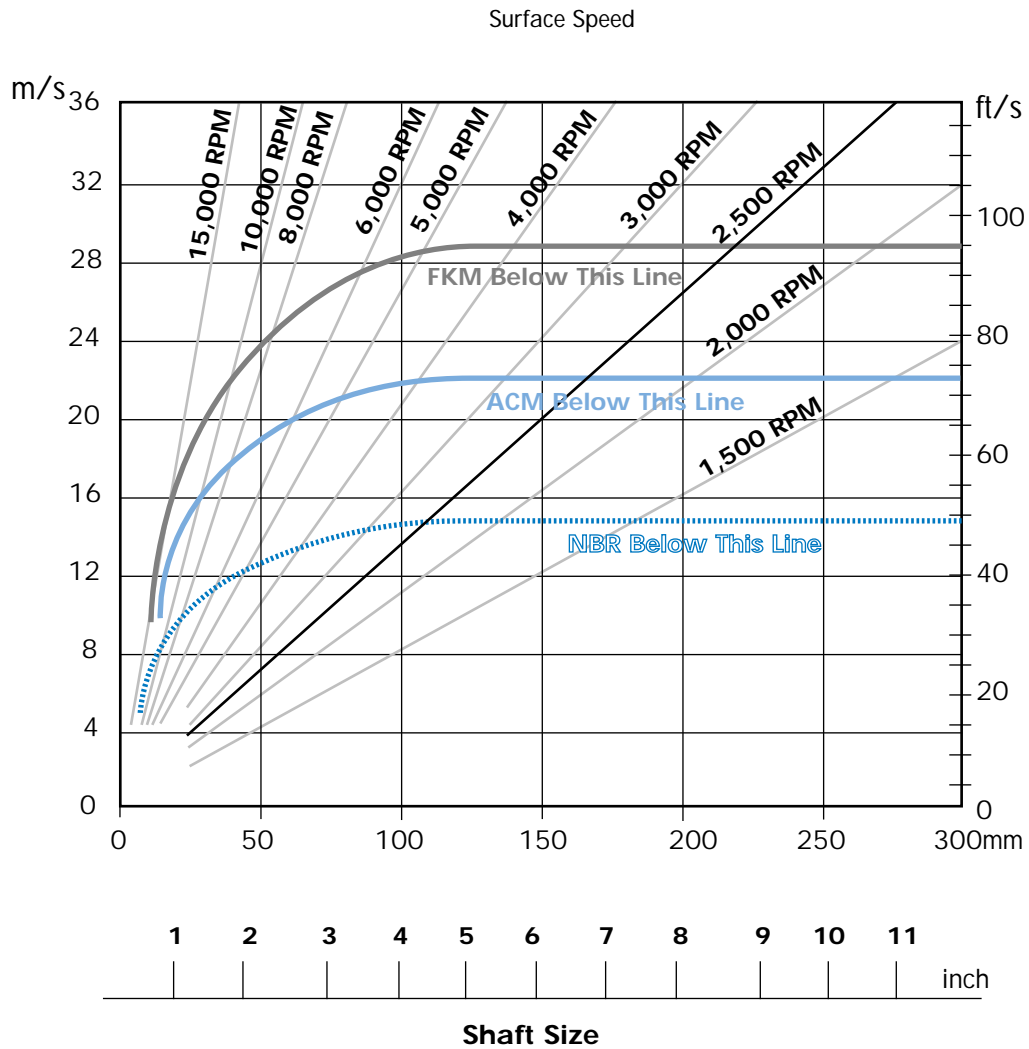

In general, the system temperature increases as the shaft speed increases. The above chart provides general recommended maximum shaft speeds for each of the common lip seal materials.



Eccentricity General

Offset (Static eccentricity)

Deviation of the offset, or deviation of concentricity between the shaft and the receiving bore, leads to irregular distribution of contact pressure and to a skewed positioning of the shaft within the shaft circumference. This migration to one side of the sealing lip leads to a greater width contact track and the loss of contact pressure on the opposite side. This impairs the sealing function.

(See Total Eccentricity Limits)

Run-out deviation

Run-out deviation, or dynamic eccentricity of the shaft (shaft whip) is to be avoided as much as possible. At high revolutions the possibility exists, because of its inertia, that the sealing lip will no longer follow the shaft. The enlarged sealing gap between the sealing edge and the shaft will lead to a certain level of leakage.

NOTE: Bearing play is to be reduced as much as possible due to the fact that the seal is typically located in direct proximity to the bearing.

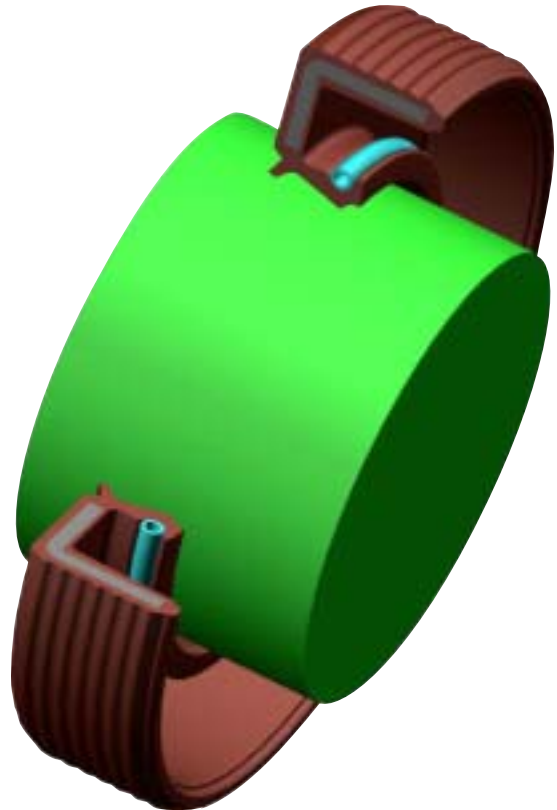

Eccentricity Limits

Total Eccentricity Limits

Total eccentricity consists of two components: shaft run-out and shaft-to-bore misalignment (offset). Combine these two figures to obtain the maximum eccentricity that the seal must follow as the shaft rotates. As eccentricity increases or shaft speed increases, it becomes more difficult for the seal lip to maintain contact with the shaft.

The total recommended eccentricity (static offset plus dynamic run-out) limits for most oil seals is shown below for different size shafts and speeds. Note that more extreme eccentricity levels can be met with special designs.

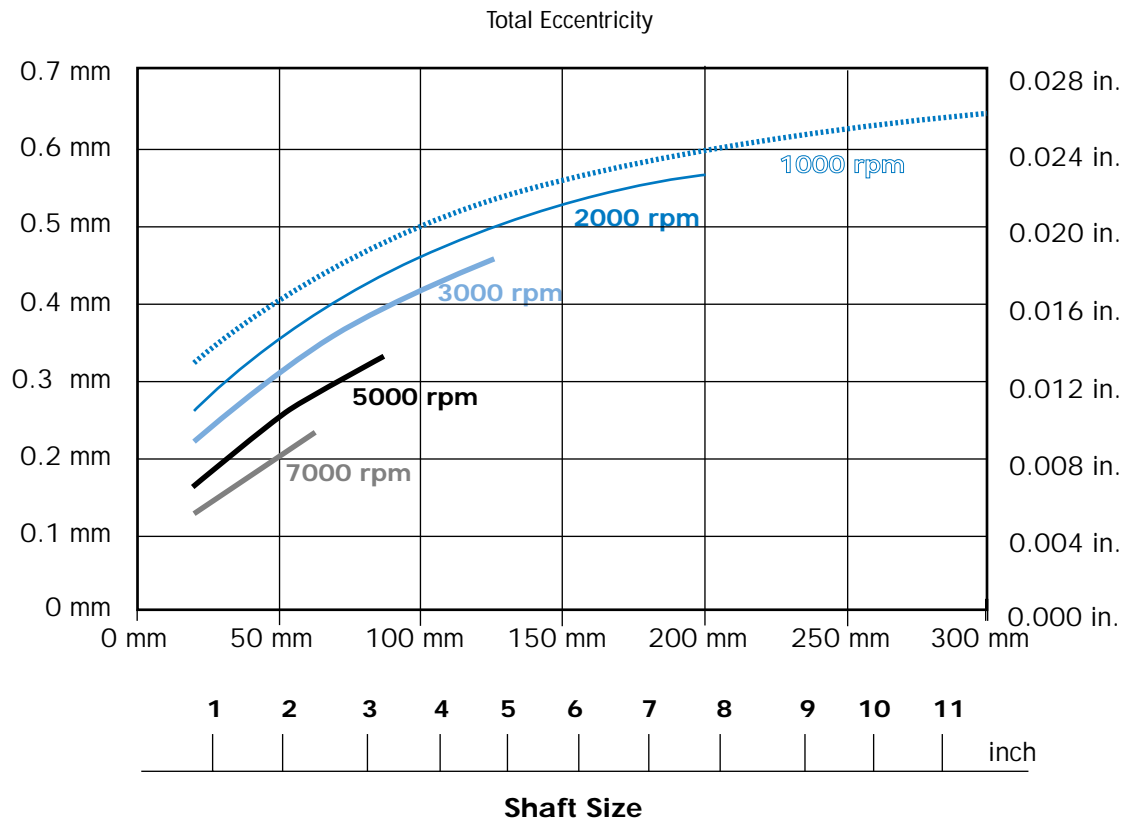

Run-out and Offset

Eccentricity

Total eccentricity is the combined total of Run-out and Offset as depicted in the following graphs:

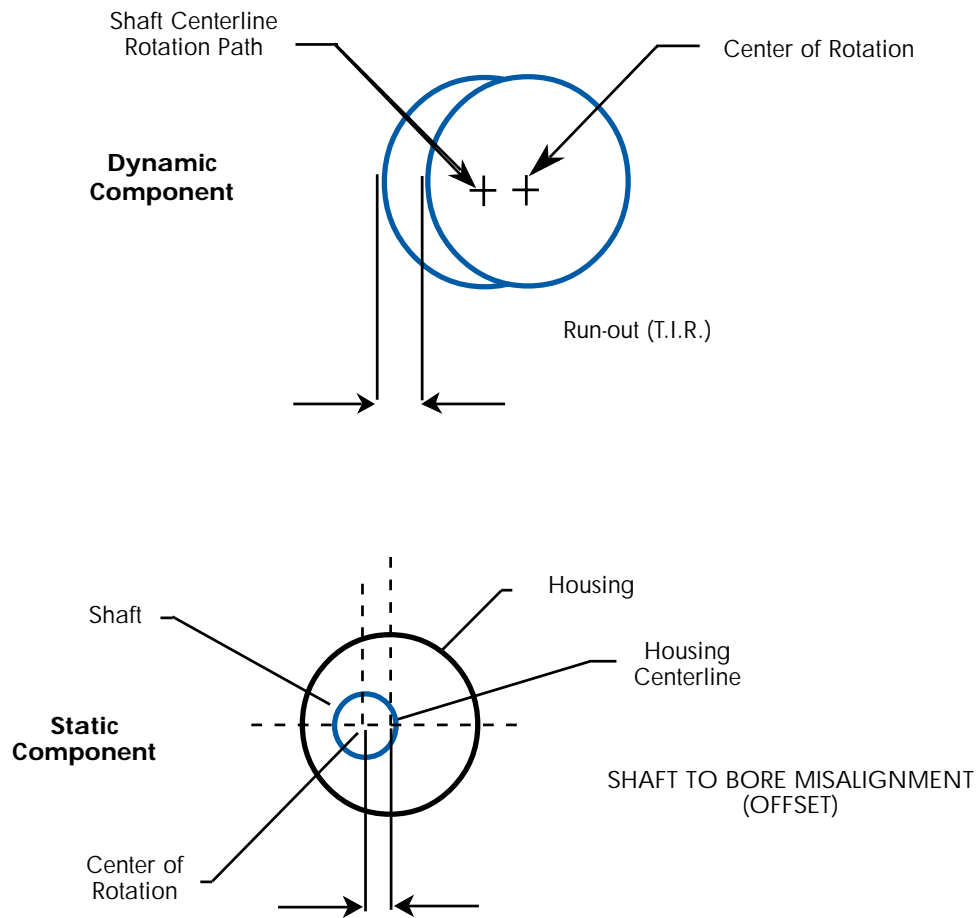

Radial Shaft Seals

STRIKING A DELICATE BALANCE

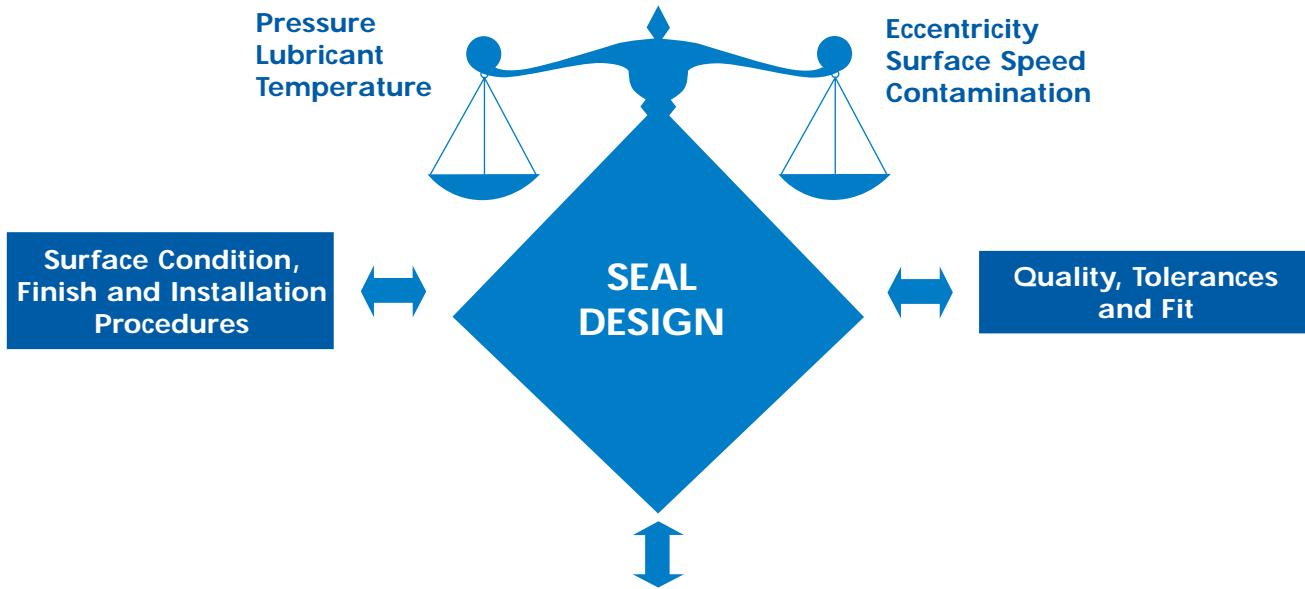

Pressure Seals

- Seal must resist lip deformation to minimize friction, wear and heat.
- Seal material should have high mechanical strength
- Special retention and support mechanisms may be required to prevent seal extrusion.

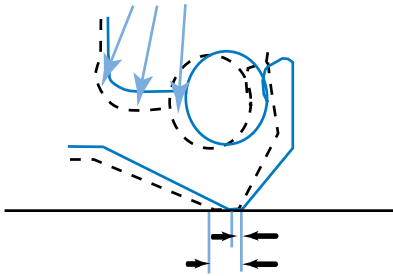

Pressure deformation causes increased seal contact with the shaft, thus increasing friction, heat generation, and wear.

There are special issues that must be addressed when dealing with pressure seal applications.

- The seal must resist lip deformation from internal fluid pressure to minimize friction, wear, and heat.
- Seal material should have high mechanical strength.
- Special retention and support mechanisms are usually required to resist seal back-out and extrusion.
- System eccentricities need to be more carefully considered than with non-pressure seals.

simrit[®]

Pressure Seals

Standard pressure seals

Our Simrit Radial Shaft Seals are primarily designed for applications that do not involve pressure or for an application with very low pressure (below 5 psi).

However, unique to our industry, Simrit does have a standard line of seals that will handle pressures below 150 psi. (TCV and BABSL up to 50 psi; TCN up to 150 psi, dependent on shaft speed.)

A feature of this seal is its short, but nevertheless, flexible lip. This special design prevents the increase of the sealing lip contact pressure and consequently the frictional behavior.

With intermittent pressure it is possible to use pressure seal designs as the dust lip prevents suction from the air side. However, when low atmospheric pressure is part of the application equation, the use of a second seal with the sealing lip directed to the air side may be required.

The lubrication of the sealing lip by a barrier liquid ensures the sealing of a vacuum. This lubrication works against the vacuum and adds resistance to the seal through pressure; the use of a TCV or BABSL style seal is recommended in this instance.

Note: *All pressure-resistant Simrit radial shaft seals must be sufficiently secure on the non pressurized side to guard against squeeze-out from the bore.*

Pressure Limits

Pressure Seal Designs

Simrit has standardized designs for low to medium pressure applications (under 150 psi).
This is unique in the industry!

**Pressure Limit Recommendations for
Simrit Standard Seal Types**

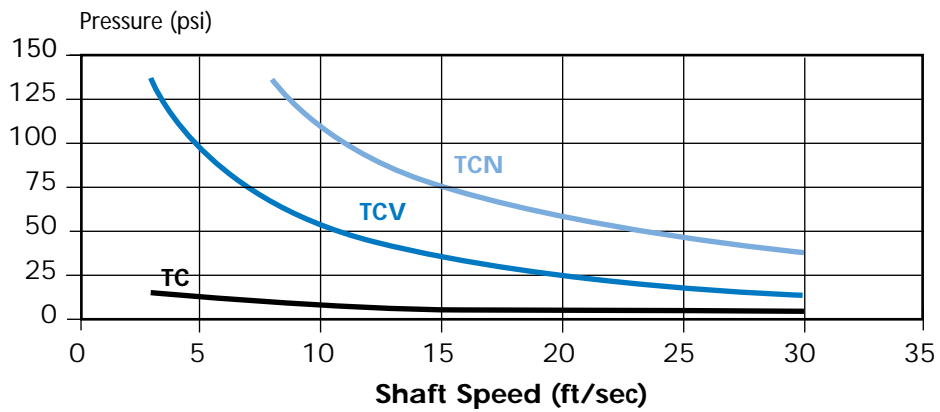

**Estimate of Seal Life for a TCV Type Seal in
FKM & NBR Materials**

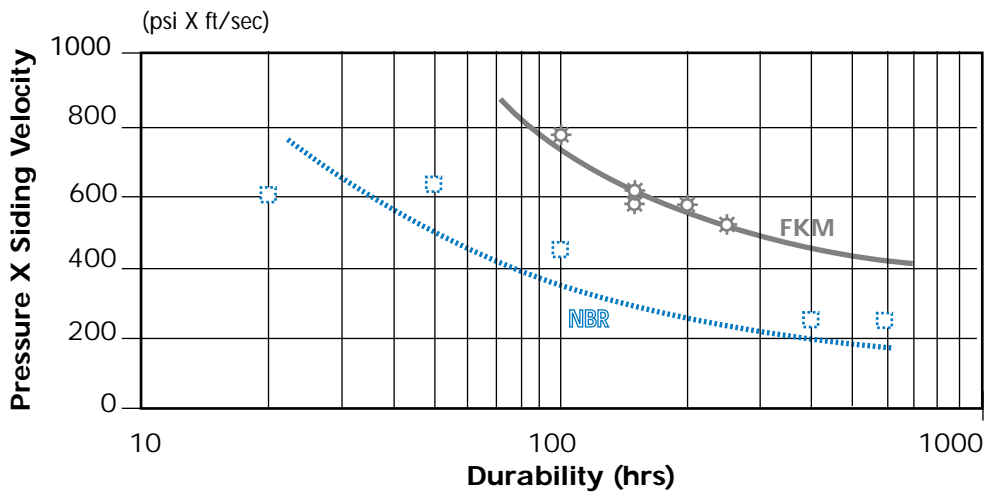

Pressure Seals Capabilities

High Pressure Designs

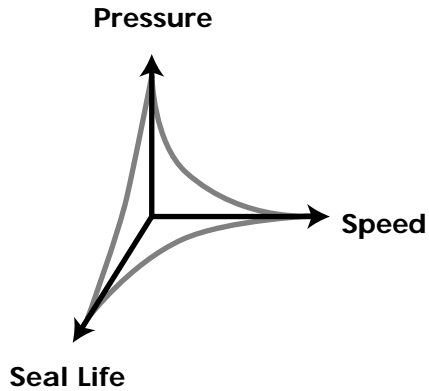

As pressure and shaft speed increase, seal life decreases

Freudenberg-NOK Pressure Seal Capability

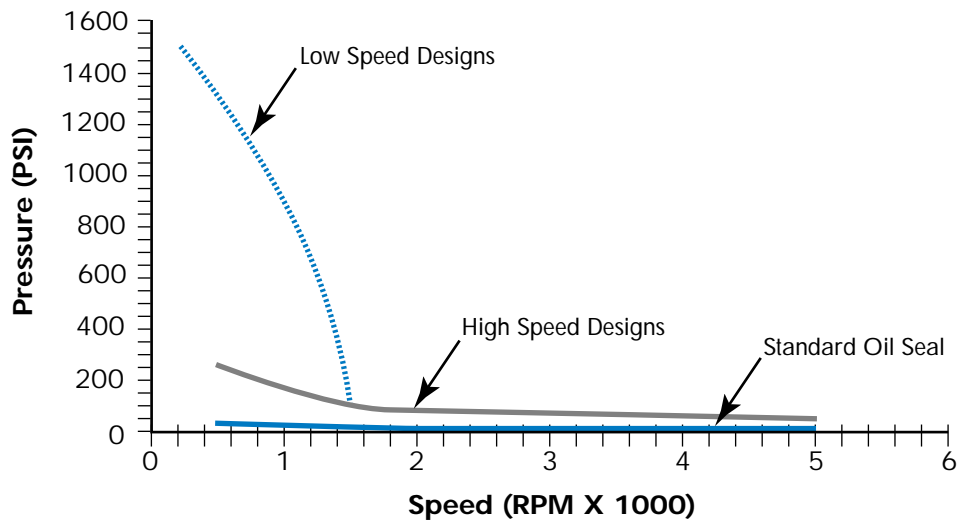

With the addition of increasing internal pressure to the seal operating conditions, seal life becomes dramatically reduced due to the added friction and heat unless the seal is designed to accommodate the pressure. Simrit has several different seal designs that have a proven track record in a variety of pressure and speed applications where standard designs will not work. Please contact your Simrit representative for assistance.

Radial Shaft Seals

STRIKING A DELICATE BALANCE

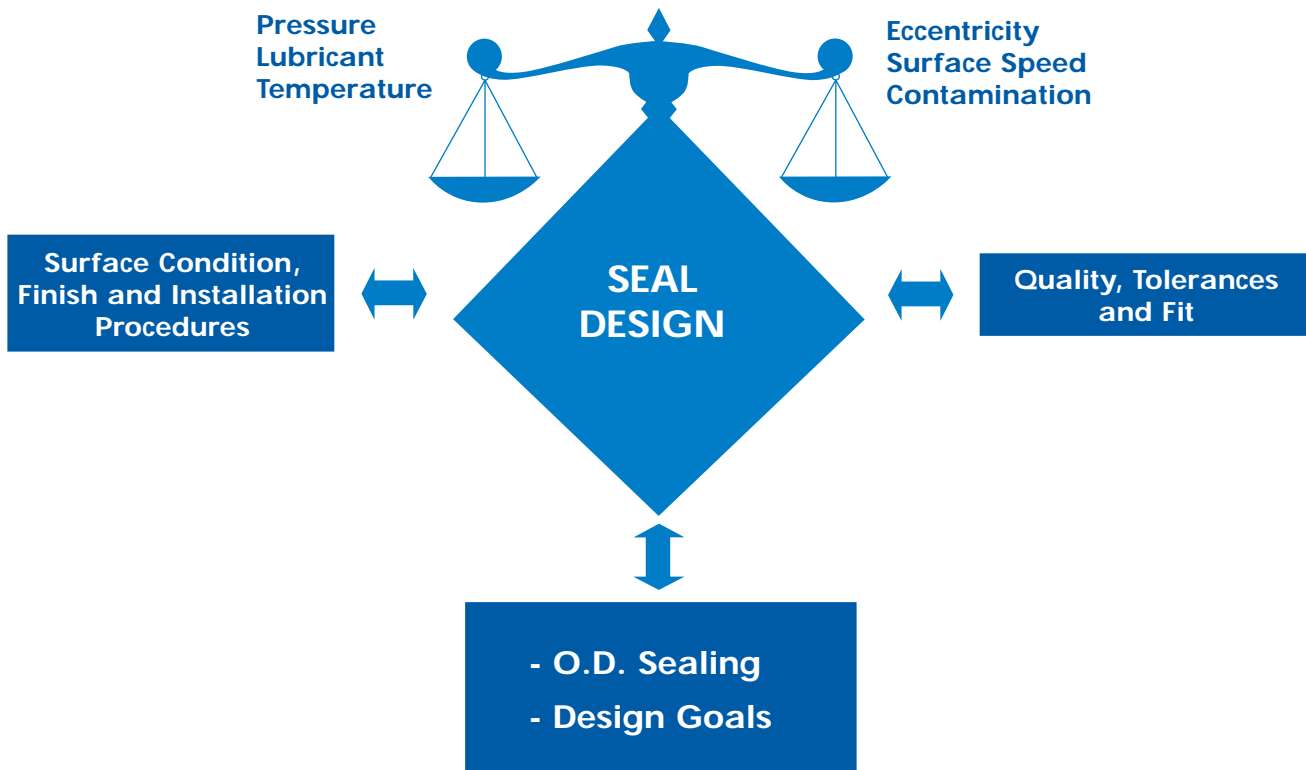

O. D. Sealing

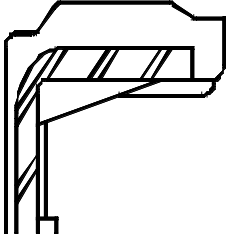
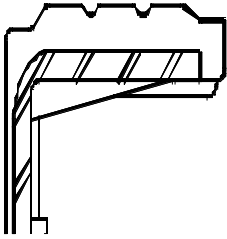
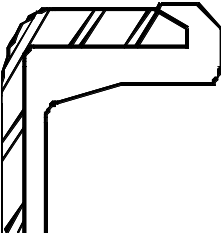
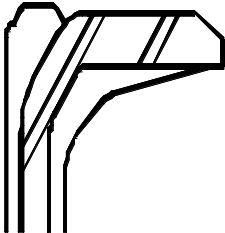
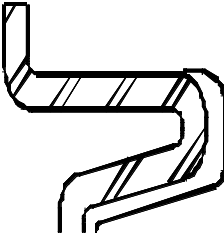
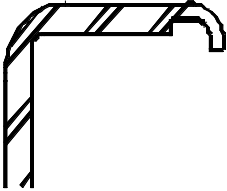
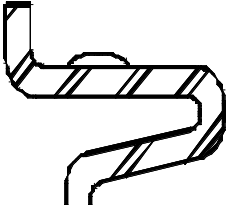
Type	O. D. Cross-Section		
Rubber			
Rubber & Metal Combined			
Metal			

NOTE: Many custom shapes and configurations are available.



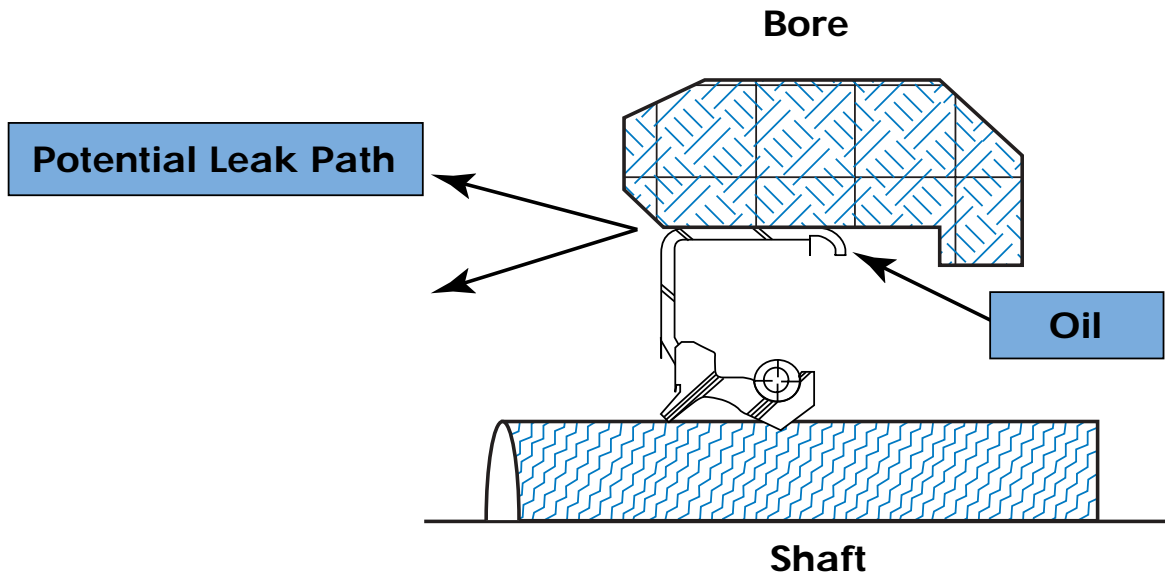













O. D. Sealing



Design Goals - SEAL MUST:

- Prevent leakage at outer diameter.
- Not rotate or come out of the bore.
- Be compatible with the bore material.
- Be easy to install.
- Compensate for bore imperfections.
- Be suited for automated installation.

O. D. Sealing Summary

Seal Design Condition	Rubber O.D.	Rubber & Metal Combination	 Metal O.D.
Non-Ferrous Housing			
Rough surface, Scratches or Nicks in the Housing			
Field Replacement			
Pressure Applications	 		
Corrosion Resistance			

KEY



Excellent



Good



Fair/Poor



Back-up support
required for retention



Latex coating lacks
elasticity and provides
little additional benefit

Radial Shaft Seals

STRIKING A DELICATE BALANCE

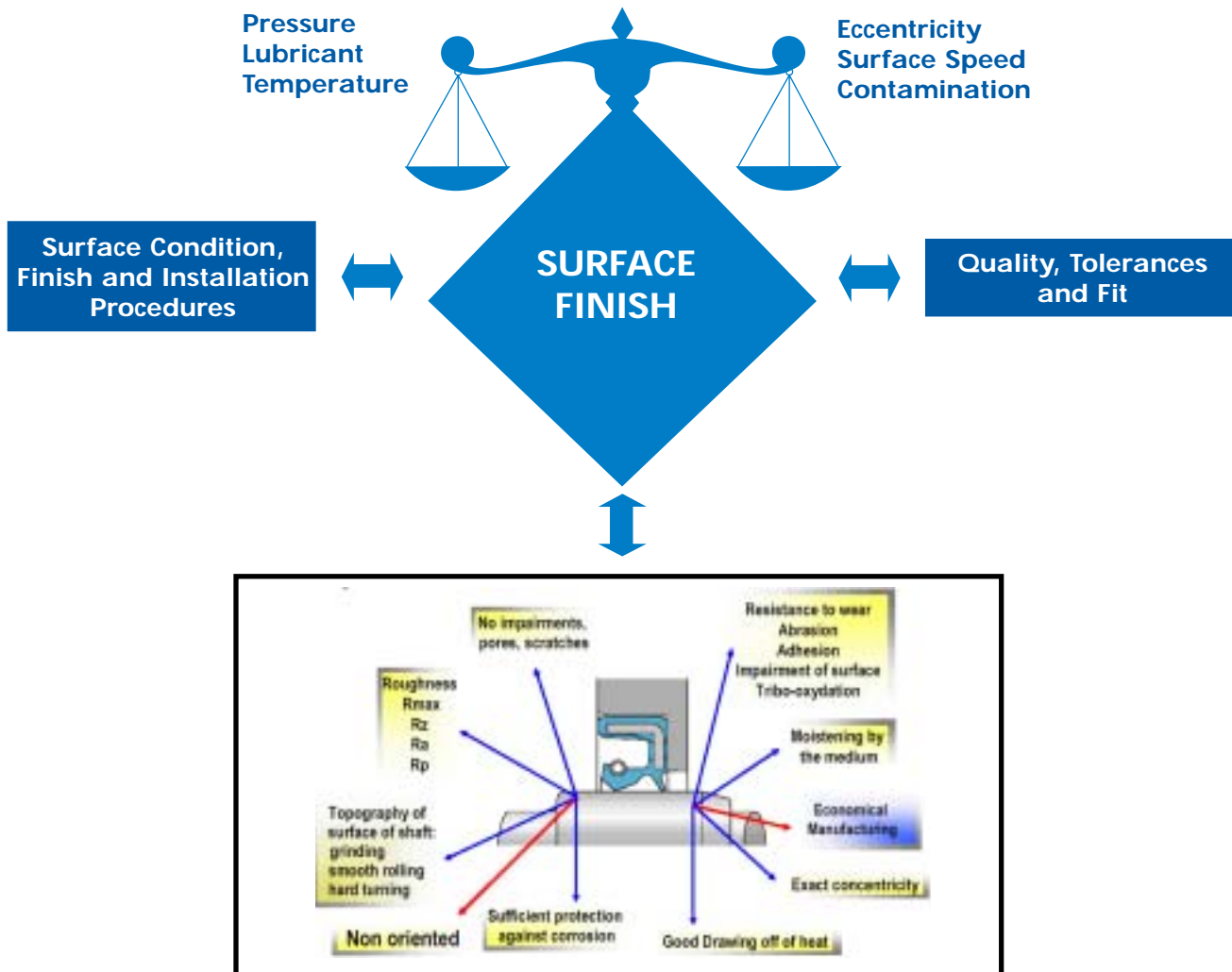

The condition of the shaft is as important as the condition of the seal if proper sealing and long life are to be achieved. Care must be taken to specify the proper design and process parameters for production of the shaft. Also, adequate care in handling and protection of the sealing surface must be followed, as handling damage to the running surface is one of the most frequent causes of seal leakage.

Structure of the Shaft

Structure of the Shaft

The structure of the shaft as it relates to the surface area at point of contact with the sealing lip, directly impacts the function of the seal and the durability of the sealing system.

Surface roughness

When the depth of roughness is too low (especially with higher surface speed), the potential for problems exist due to the inability of the lubricant to effectively reach the sealing edge. This can result in premature hardening and the formation of cracks and possibly signs of combustion on the sealing edge.

When the depth of roughness is too high the potential for problems exists with excessive premature wear and possible leakage within the sealing system. (**See Recommended Shaft Conditions**)

Plunge Grinding

The recommended procedure in shaft preparation is plunge grinding. This is to ensure the desired non-oriented state of the shaft. (***Plunge Grind Process***)

Shaft Materials

Suitable materials to ensure the proper function of our Simrit Radial Shaft seals are:

-The steel usually found in mechanical engineering, e.g. C35 and C45

-Casting materials such as ball graphite and malleable iron.

-Sprayed on metal coatings

-Coatings applied through CVD and PVD processes, as well as, anodized coatings positively assessed

The adherence to values for roughness and a good adhesion to the base material are prerequisites.

Note *generally* suitable are:

-Hard chrome coatings

-Plastic materials

Shaft impairment

Scratches, pressure sites, rust and other damage on the seal's running surface ultimately leads to leakage problems.

Note: Great care in protecting the shaft during production and through to final assembly is recommended. This can be accomplished by using protective sleeves and special transporting devices.

Conditions

Recommended Shaft Condition

Surface roughness 10- 20 micro inch R_a , $R_{max} < 126$ micro inch.

Shaft hardness minimum 45 Rockwell C

No machine lead permitted (plunge grinding recommended)

Seal contact area to have no scratches, nicks, or defects and be free of contamination

When installing seal over a spline, a protective cover should be used

Seal diameter < Bearing diameter

Seal diameter > Spline diameter

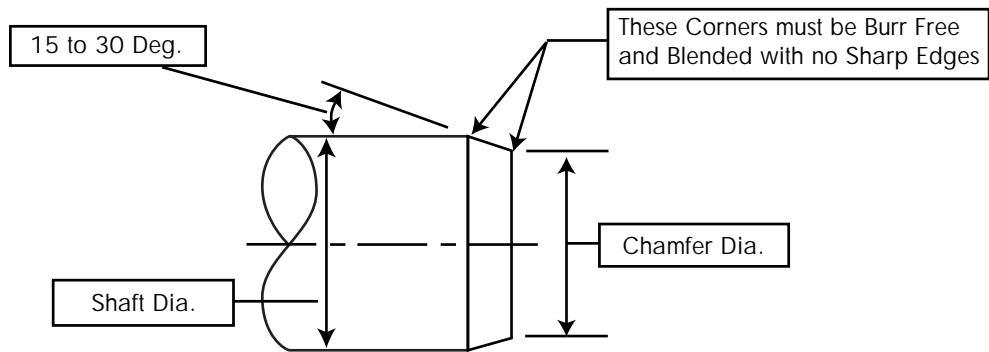

SHAFT DIA. (SD) (Inches)	CHAMFER DIA. (Inches)	SHAFT DIA. (SD) (mm)	CHAMFER DIA. (mm)
0.000 to 1.000	SD - 0.094	0.00 to 25.00	SD - 2.4
1.001 to 2.000	SD - 0.140	25.01 to 50.00	SD - 3.6
2.001 to 3.000	SD - 0.166	50.01 to 75.00	SD - 4.2
3.001 to 4.000	SD - 0.196	75.01 to 100.00	SD - 5.0
4.001 to 5.000	SD - 0.220	100.01 to 125.00	SD - 5.6
5.001 to 6.000	SD - 0.260	125.01 to 150.00	SD - 6.6
6.001 to 10.000	SD - 0.276	150.01 to 250.00	SD - 7.0

Plunge Grinding

Plunge Grind Process

- No Traverse
- Approx. 80 grit grinding wheel will produce a 10 to 20 micro inch finish
- Uneven ratio of grinding wheel speed to work piece speed required
- Must remove entire base finish

Advantages

- Short to medium grind marks
 - *good for lip lubrication*
- Lay is perpendicular to the shaft axis
 - *no lead angle*

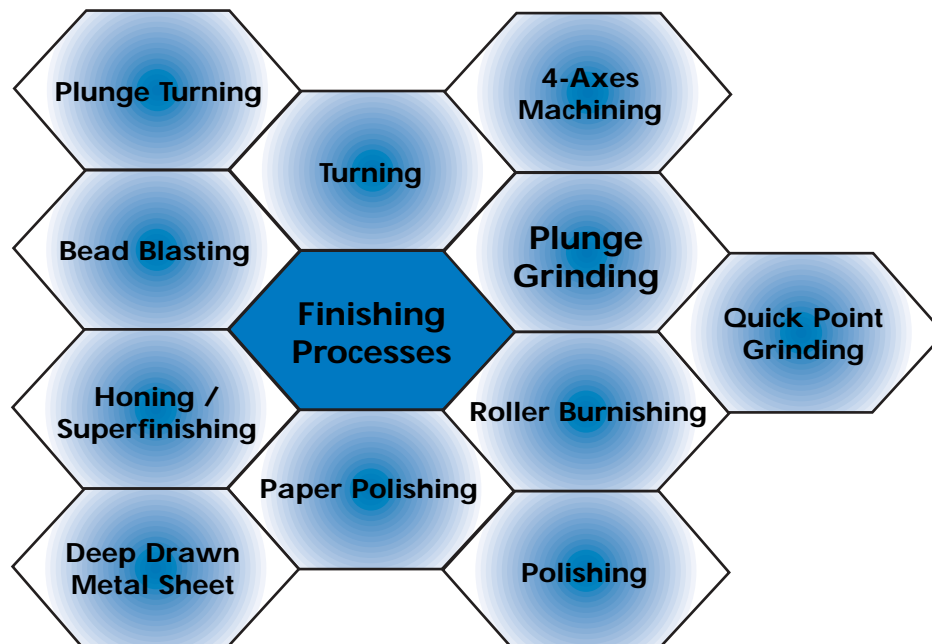

Housings

Housings

Steel and cast iron provide good surfaces for both rubber covered and metal O.D. seals. For soft alloy (aluminum) bores, rubber covered O.D. seals provide better sealing capability. In aluminum or other soft alloy bores, metal O.D. seals occasionally back out of the bore due to thermal expansion of the soft alloy. Rubber, having a higher coefficient of thermal expansion than carbon steel, will tighten in the bores as temperature rises.

Metal O.D. seals are not recommended for use in plastic or nylon housings. These materials typically expand at a high rate causing leakage around the seal O.D. Rubber covered O.D. seals should be used in these situations.

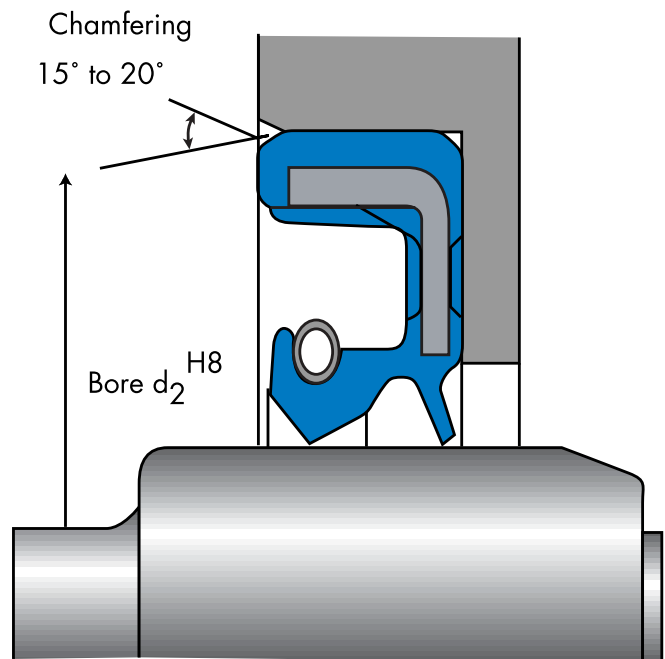

Bore Chamfer

A bore chamfer is necessary to assist in installation of the seal. Proper chamfer angle and depth minimizes cocking or lack of squareness of the seal to the shaft, distortion of the seal cases, and reduces assembly force.

Bore Material & Finish

Influence of the Bore Material and Surface Finish

In non-ferrous or plastic housings metal O.D. seals lose pressfit at elevated temperatures due to differences in thermal expansion.

Material	Coefficient of Thermal Expansion ° C
Carbon Steel	12×10^{-6}
Aluminum & Magnesium	24×10^{-6}
Plastic (Nylon)	$30 \sim 300 \times 10^{-6}$
Rubber	$100 \sim 200 \times 10^{-6}$

Rubber O.D. seals can tolerate higher levels of initial bore finish than metal O.D. types.

Metal O.D. Design	Rubber O.D. Design
100 micro inch R_a	150 micro inch R_a
(2.5 micro meter R_a)	(3.75 micro meter R_a)

Housing Recommendations

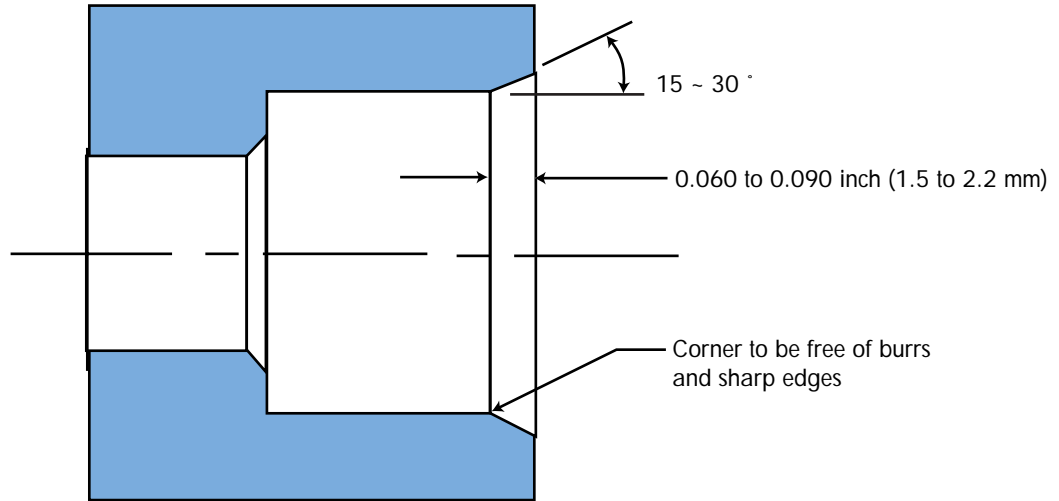

Max Bore Surface Roughness

METAL O.D.	RUBBER O.D.
100 micro inch R_a (2.5 micro meter R_a)	150 micro inch R_a (3.75 micro meter R_a)
492 micro inch R_{max} (12.5 micro meter R_{max})	

NOTE: With aluminum and magnesium bores, a minimum roughness of 60 micro inch R_a (1.5 micrometer R_a) is recommended for improved retention of rubber O.D. seals.

Radial Shaft Seals

Contamination Exclusion Features

STRIKING A DELICATE BALANCE

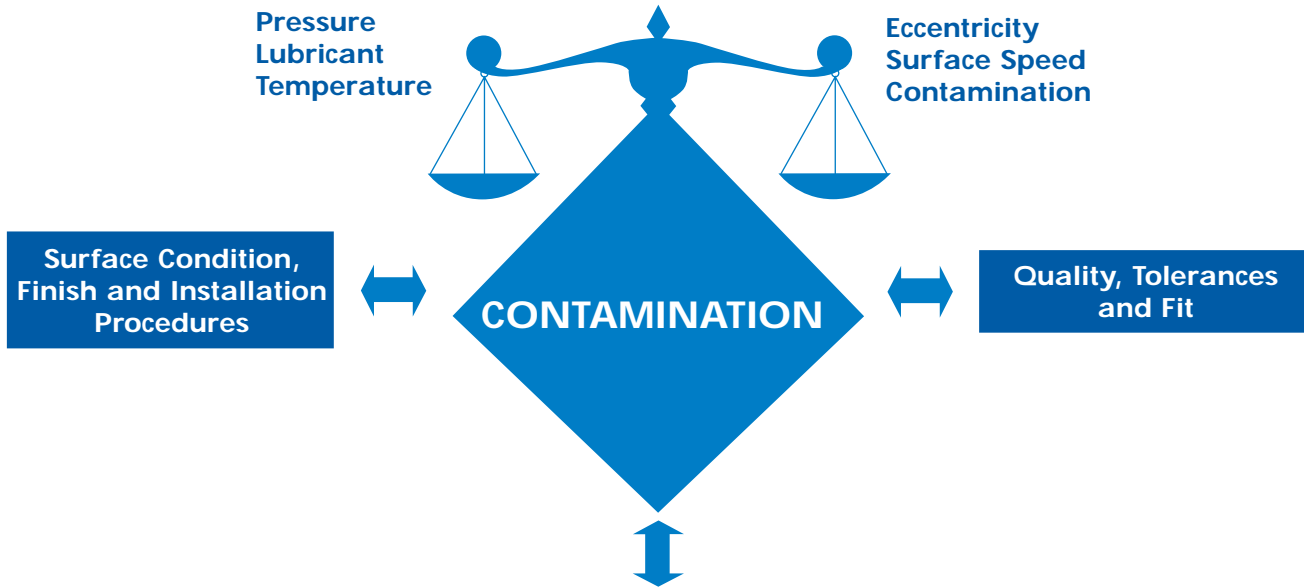

EXCLUSION FEATURES

Seal must be capable of stopping any outside contamination from:

- damaging/grooving the seal's main lip
- ingesting into the oil

Added exclusion features should not generate excessive heat in high speed applications

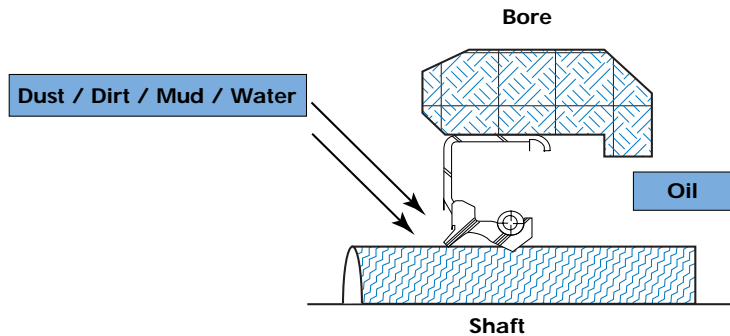

Contamination Excluder Designs

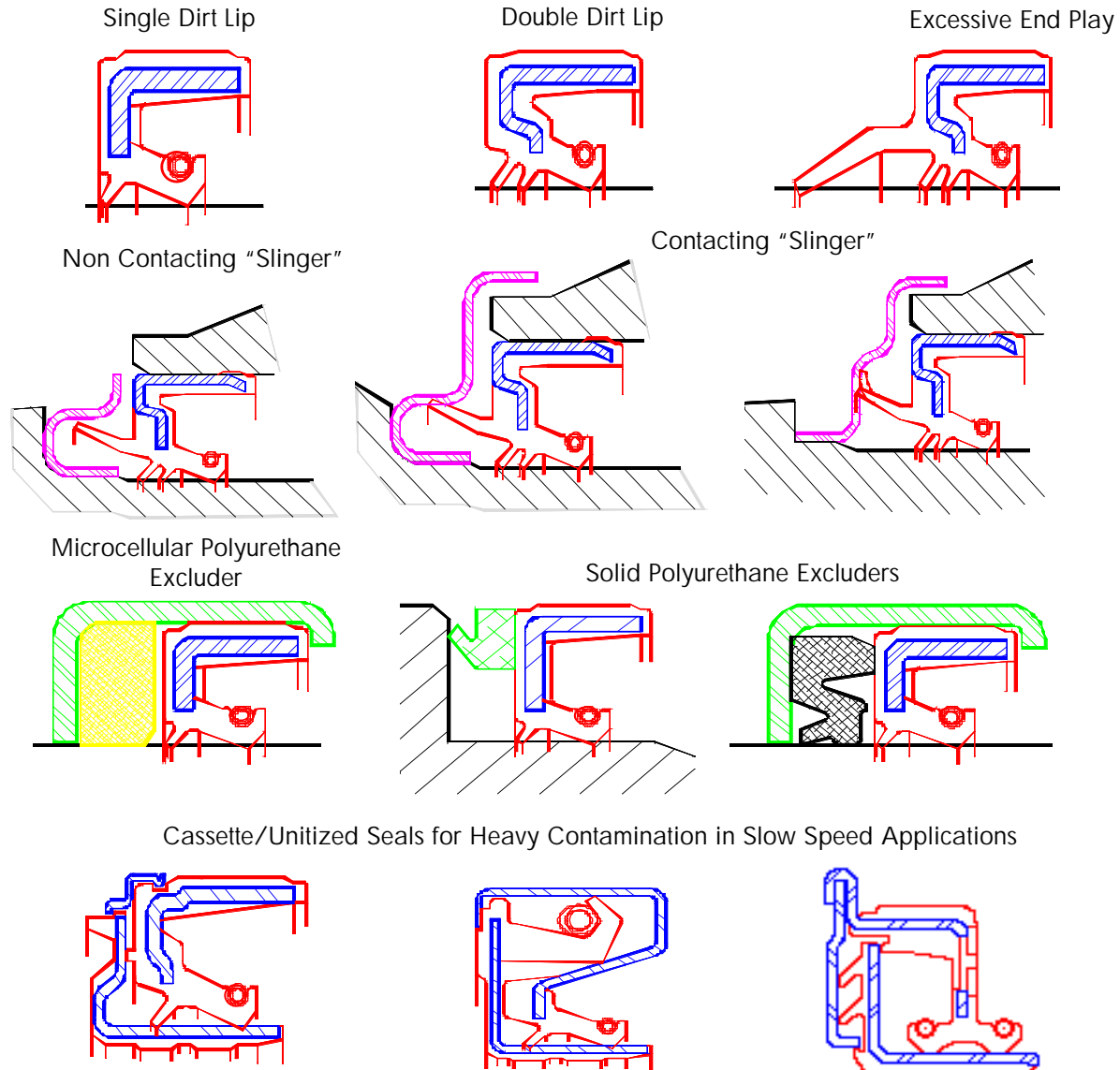

Many special designs can be provided to fit your application. If the sealing environment is harsh, we recommend you contact a Simrit representative to review the need for added exclusion features

simrit[®]

Radial Shaft Seals

STRIKING A DELICATE BALANCE

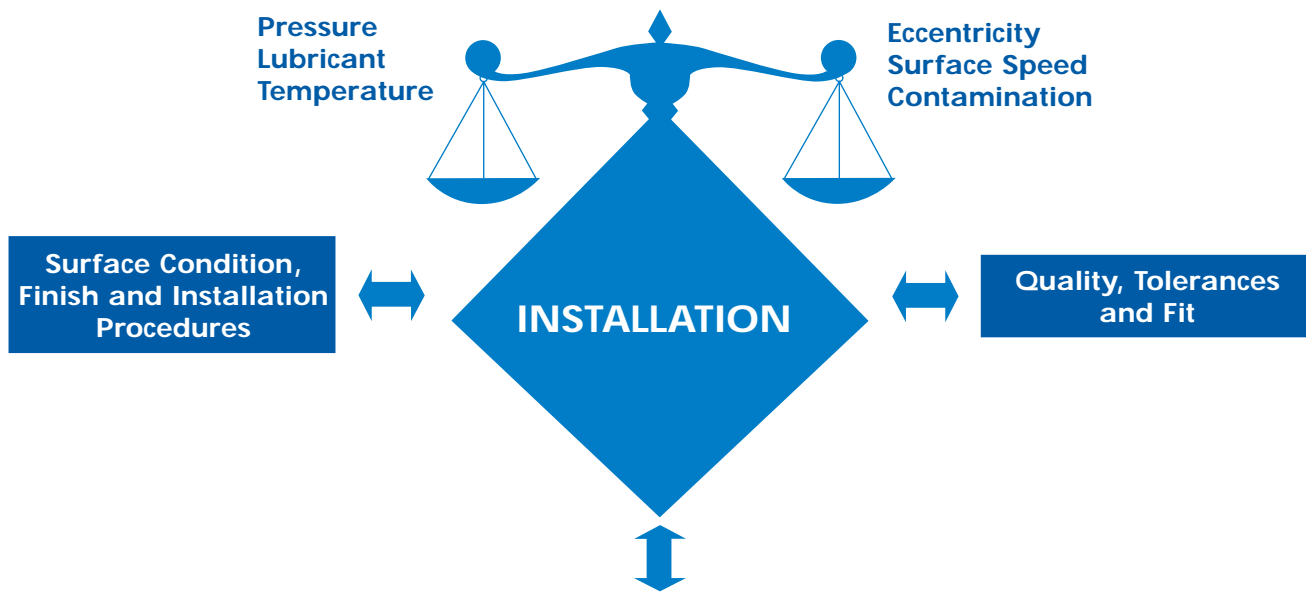

CRITICAL ISSUES

Installation problems frequently are diagnosed as the cause of leakage. In order to ensure optimum seal function the seal must be properly installed. Care must be taken to:

1. Design the O.D. of the seal appropriately for the application
2. Design the housing to accommodate the seal
3. Follow recommended handling and installation procedures

Installation Procedures

Proper Installation Procedures

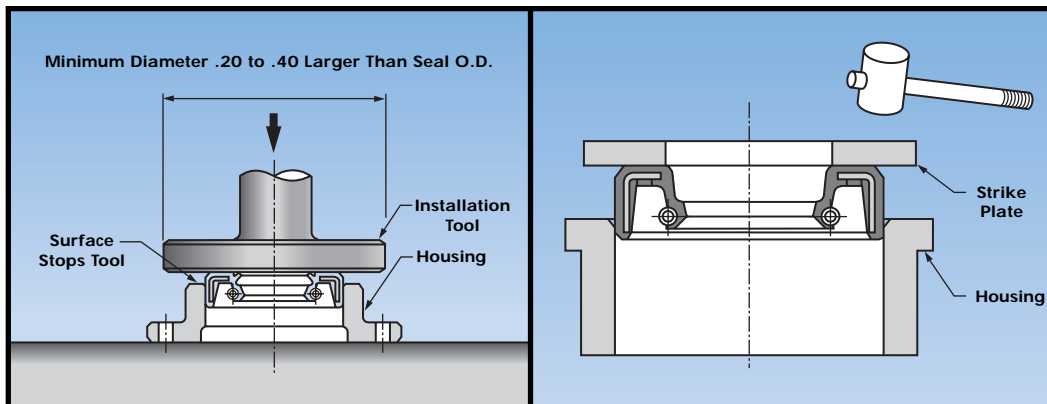
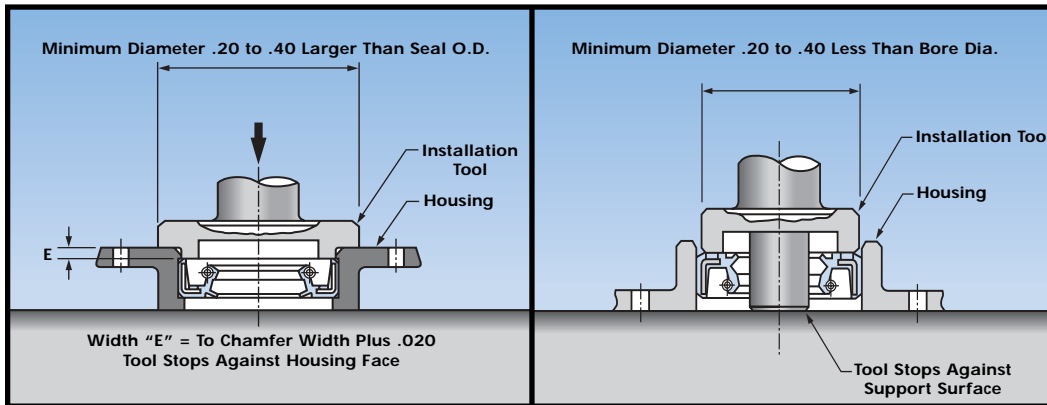

Improper Installation

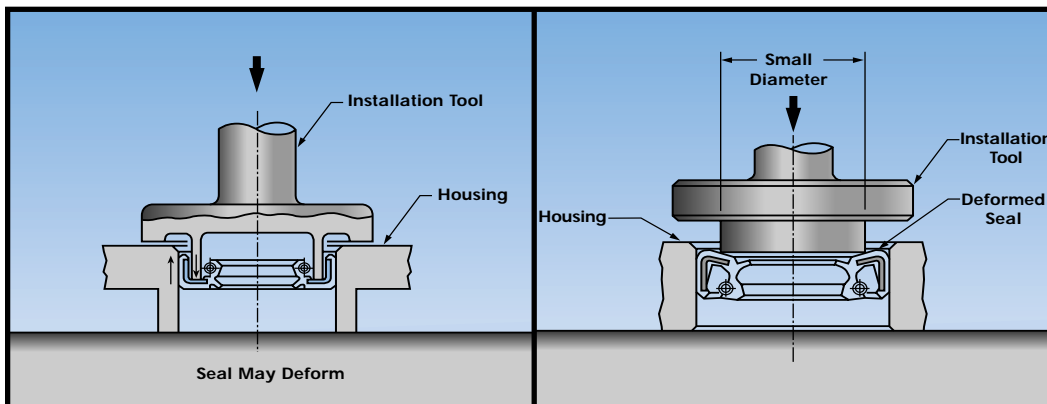

Installation Procedures

Installation Over Splines

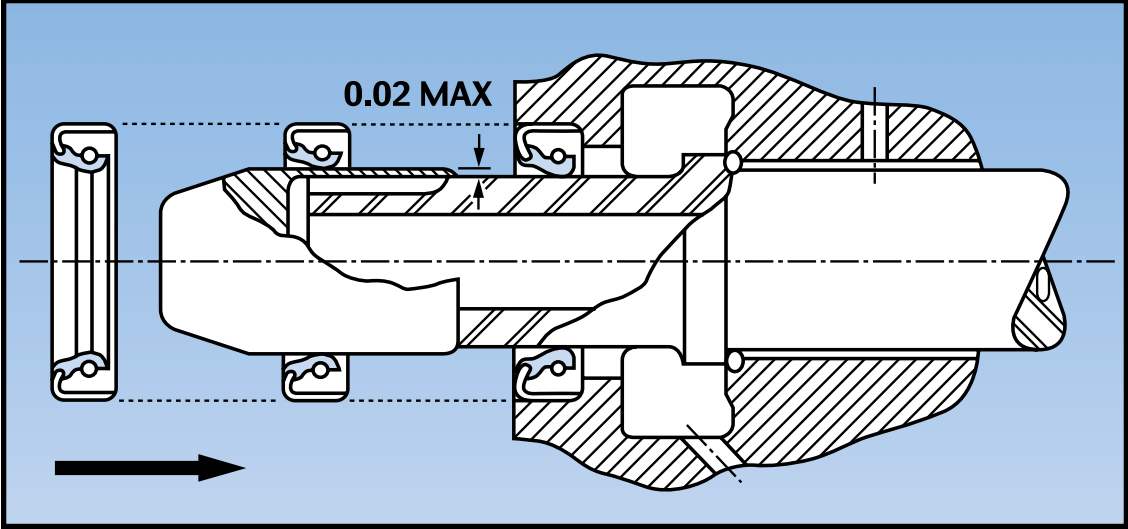

Heavy Duty Housing

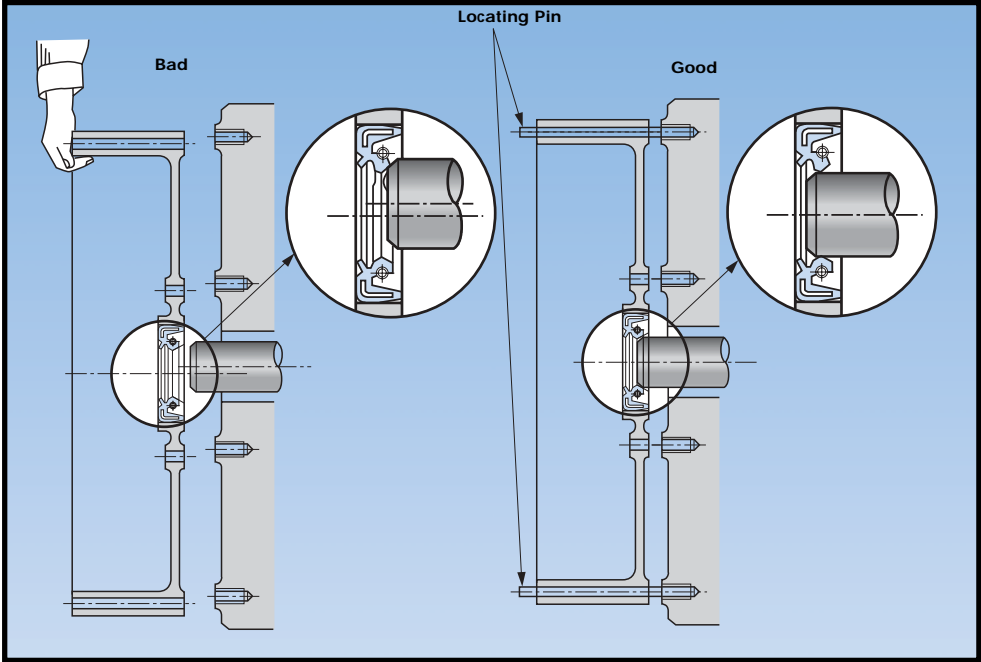

Installation Procedures

Long Shaft

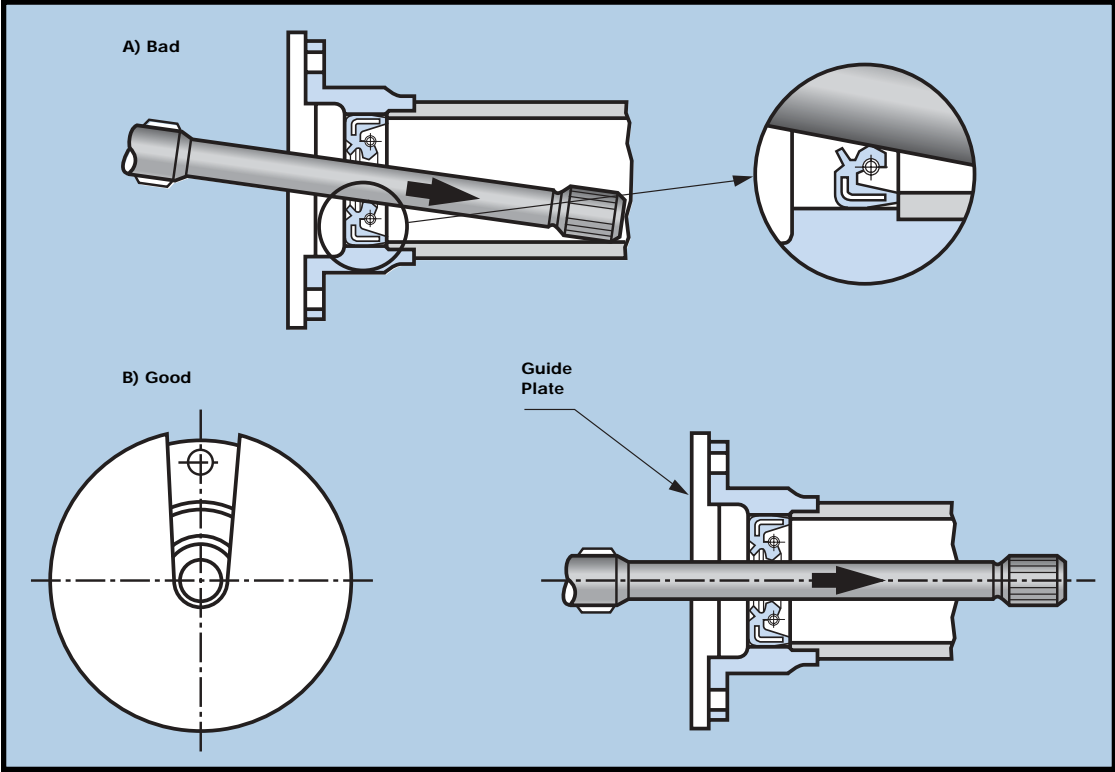

Leakage - General

Leakage

There are different and varying terms to define what is classified as "leakage".

- Watertight: No moisture on seal
- Moist: bead of moisture in sealing edge area limiting the function, but not going beyond back surface area
- Wet: bead of moisture going beyond back surface area with the formation of droplets, but not dripping
- Measurable
Leakage: small beads of moisture on outside of housing coming from the back of the seal
- Passing
Leakage: short-term problem within the sealing system, e.g. caused by small dirt particles under the sealing edge which will wash away with further use.
- Apparent
Leakage: passing leakage which leads back to the grease filling between the sealing lip and dust lip. The overflowing grease appears as apparent leakage on the outside.

Causes for measurable leakage can be:

- Varied expansion of seal and housing on the static side by non-adherence to tolerances.
- Cracks in the material, above all in the sealing edge due to exceeding seal operating limitations.
- Increasing hardness of rubber caused by exceeding seal working parameters and incompatibility with the media being sealed.
- Corrosion from the shaft up to the sealing edge.
- Failure of lubrication thereby seal runs dry; result is excessive wear on the sealing lip.
- Formation of "oil carbons" in the sealing edge area.
- Vibration of the unit and shaft to such an extent that the sealing lip can no longer follow.
- Permanent ingress of dirt on the sealing lip from either inside the chamber or out.
- Damage due to handling or installation.

Leakage - General

Probable Causes of Seal Failure

Short Term / Warranty

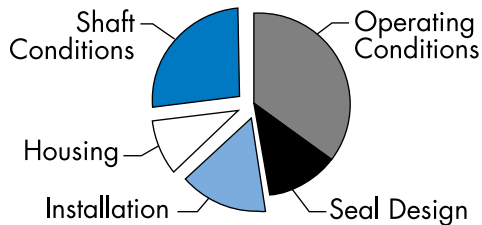

Long Term / Durability

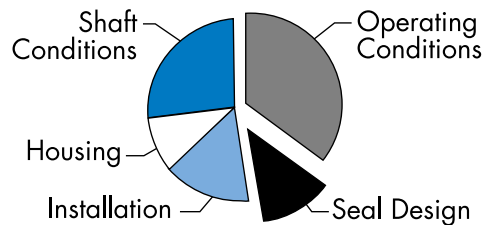

The user has primary control over the variables influencing short term or warranty failure. The condition of the shaft and housing, operating parameters and installation play large roles in determining the short term warranty factors.

Simrit and the seal user share responsibility for the sealing system's long term durability. While the shaft and housing preparation and installation of a seal are primary factors involving the user, Simrit works with the customer in designing a seal that meets the operating conditions outlined by that user. These combined factors will determine the long term durability of the sealing product.

Leakage - General

Warranty Avoidance Checklist

1. Prepare proper housing bore diameter and chamfer.
2. Prepare proper shaft diameter and chamfer.
3. Ensure appropriate prelubrication (usually the lubricant being sealed).
4. Use a hydraulic press or other suitable method to ensure proper force and speed are applied.
5. Use proper tools.
6. Install the seal contaminant and damage free:
 - a. Open only 1 package of seals at a time;
 - b. Installation area must be kept clean;
 - c. Tools, protective sleeves, and bullets must be kept clean and periodically inspected for damage.

What Should I Look For?

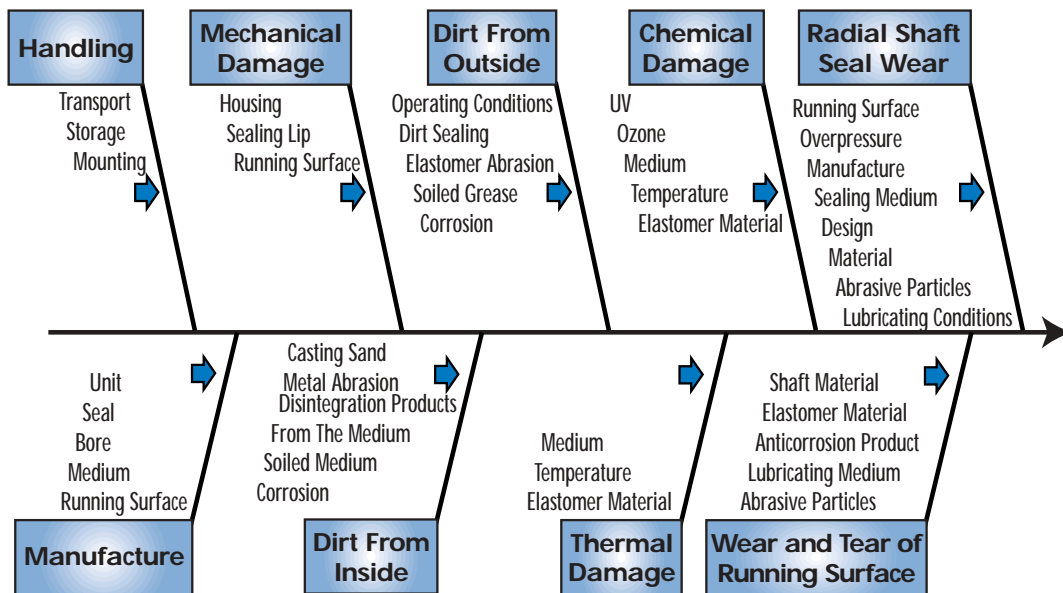

Defect Sources

Defect source and recommended remedial measures

Incoming Goods:

Defect Source:	Damage to packaging
Possible Defect:	Contamination of Shaft Seals
Consequence:	Shortened service life or immediate leakage
Weak spot:	Packaging not satisfactory
Remedial Action	Set procedures for inspection of parts for contamination, visual and dimensional changes, handling; optimize packaging.

Storage

Defect Source:	Damage to packaging Non-adherence to storage guidelines
Possible Defect:	Fitting and employment of contaminated shaft seals
Consequence:	No effect up to immediate leakage and possible shortened working life.
Weak spot:	Non-adherence to storage conditions
Remedial Action	Definite adherence to storage conditions

Defect Sources

Defect source and recommended remedial measures

Storage Cont'd.

Defect Source:	Contamination of Shaft Seals
Possible Defect:	Fitting and employment of contaminated seals
Consequence:	Shortened service life or immediate leakage
Weak spot:	Dust and dirt
Remedial Action	Cleaning with suitable cleaning agent before installation, original packaging to be opened only at installation site.

Storage Cont'd.

Defect Source:	Damaged shaft seal
Possible Defect:	Installation of impaired shaft seals
Consequence:	Immediate leakage or shortened working life
Weak spot:	Premature aging through improper storage
Remedial Action	Original packaging to be opened only at installation site

Defect Sources

Defect source and recommended remedial measures

Storage Cont'd.

Defect Source:	Open storing of pre-greased shaft seals
Possible Defect:	Contamination of grease
Consequence:	Shortened service life or immediate leakage
Weak spot:	Dust and dirt from surroundings
Remedial Action	Always cover packaging unit, protect from dust and dirt, only draw the needed quantity for use

Storage Cont'd.

Defect Source:	Unsuitable stock container
Possible Defect:	Contamination, impairment of shaft seals, springs coming loose
Consequence:	Immediate leakage or shortened working life
Weak spot:	Collection of dirt and moisture in the stocking container, sharp edges
Remedial Action	Use containers that are open and lightly cleaned. No sharp edges

Defect Sources

Defect source and recommended remedial measures

Preparing for Installation:

Defect Source:	Improper opening or withdrawing from package
Possible Defect:	Cuts or similar damage on O.D. Loss of spring
Consequence:	Shortened service life or immediate leakage
Weak spot:	Unsuitable tools or methods for opening
Remedial Action	Suitable tooling for opening packages, special and careful handling by installer

Preparing for Installation:

Defect Source:	Using contaminated grease when pre-greasing shaft seal
Possible Defect:	Contamination, impairment of shaft seals
Consequence:	Immediate leakage or shortened working life
Weak spot:	Dirt and dust
Remedial Action	Grease container to be protected from dust and dirt and sealed off when not in use

Defect Sources

Defect source and recommended remedial measures

Preparing for Installation:

Defect Source:	Unsuitable oil for moistening of shaft prior to shaft seal press fit
Possible Defect:	Chemical influence on seal material, stick-slip
Consequence:	Shortened service life due to accelerated wear
Weak spot:	Unfavorable lubrication, no oil in contact with Simrit shaft seal material
Remedial Action	Consult Simrit Representative about oil grade. DO NOT USE GRAPHITE GREASE

Preparing for Installation:

Defect Source:	Too much grease between sealing edge and dust lip
Possible Defect:	Appearance of grease when installing or during operation
Consequence:	"Apparent leakage"
Weak spot:	Incorrect amount of grease
Remedial Action	Maximum grease amount: +/- 40% of greasing space

Radial Shaft Seals

STRIKING A DELICATE BALANCE

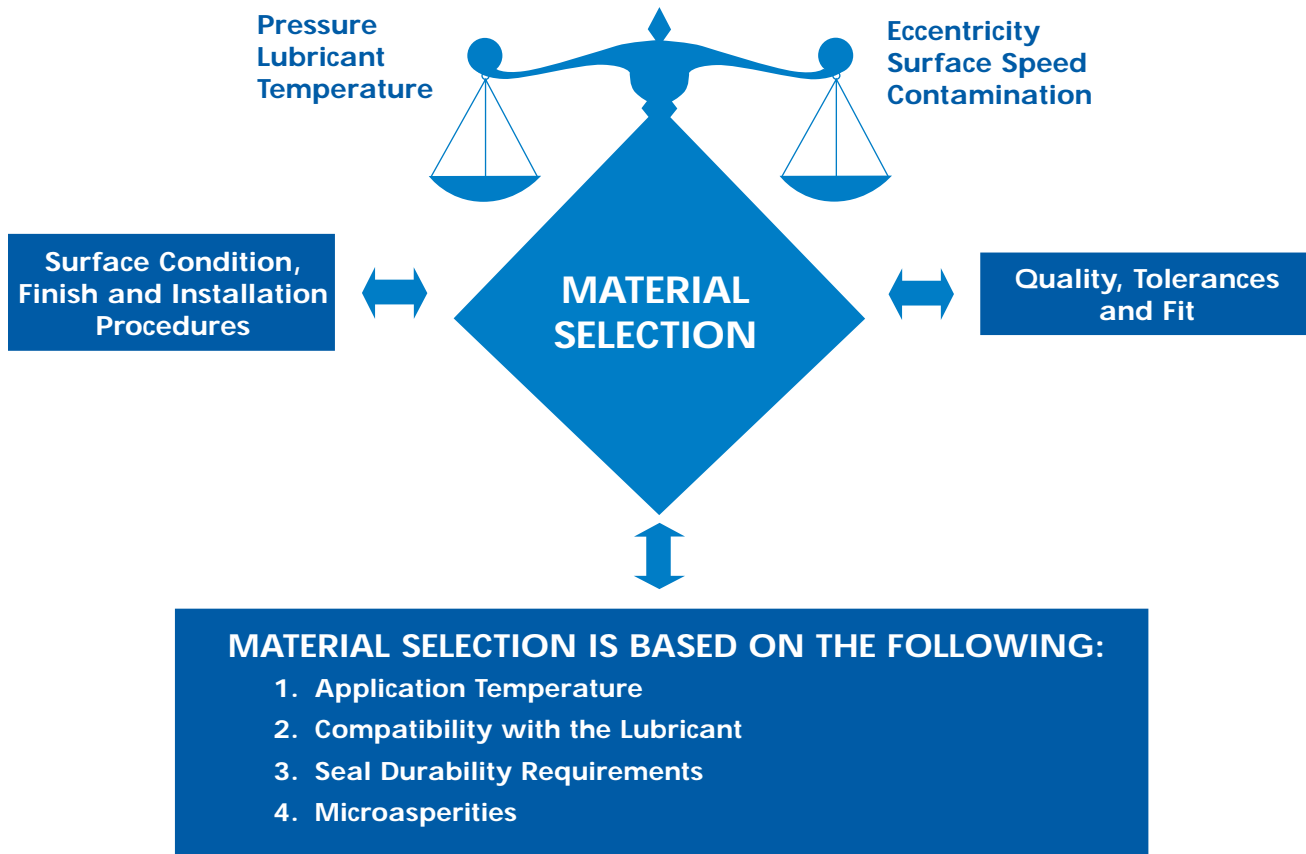

Simrit elastomers can be customized to meet specific customer requirements. We currently compound hundreds of different recipes to fit many unique applications.

Media to be Sealed

Medium and selection of material

The medium to be sealed determines the selection of Simrit material and also the selection of the seal to be used.

Sealing is possible against liquid, vapor and in exceptional cases, even low viscosity and gaseous media.

Simrit materials can seal against various lubricating substances, e.g.:

- Mineral oils
- Synthetic oils
- Greases based on mineral oils
- Synthetic greases
- Hydraulic oils
- Highly inflammable pressurized liquids
- Silicone oils with low lubricating properties

Under special circumstances, Simrit materials can seal against low lubricating, aggressive media, e.g.:

- Acids
- Alkalis
- Organic solvents

Reactions between media and Simrit materials

Chemical influences of the media on Simrit materials are crucial. Chemical reactions are accelerated by increased temperatures. Materials of any sort can harden or soften due to the media exposure.

-Hardening by ageing process caused by media

-Softening through swelling caused by the media.

Upper limit conditions

The limits imposed on applications for the Simrit radial shaft seal are reached and exceeded when several conditions meet the upper operating limits; such as:

- The maximum permitted surface speed
- The maximum permitted temperature
- Pressure resistance
- Sparse lubrication or reduced heat dissipation.

Material Selection

- VMQ Silicone
- NBR Nitrile
- ACM Polyacrylate
- FKM Fluoroelastomer
- FVMQ Fluorosilicone
- AEM Ethylene Acrylic
- PTFE Polytetrafluoroethylene
- EPDM Ethylene Propylene
- ECO Epichlorohydrine Ethylene Oxide
- SBR Styrene-Butadiene Rubber
- HSN Hydrogeneated Nitrile
- IIR Butyl Rubber
- NR Natural Rubber

At Simrit, we work with virtually every base polymer that is commercially available. This allows us to use the optimum material for each customer's application.

All of our materials are compounded in-house, giving us much better control over the material properties and allowing us to custom tailor our compound for a given application.

	NBR	ACM	VMQ	FKM	HNBR	PTFE	FPM*
wear resistance	very good	moderate	moderate	very good	moderate	good	very good
high temperature	moderate	good	very good	very good	good	good	very good
oil resistance	max. 100°C max. 80°C in heavy duty oils	max. 150°C	max. 180°C	max. 200°C (max. 150°C operating temperature)	max. 150°C (max. 140°C operating temperture)	max. 200°C	max. 200°C (max. 140° operating temperature)
low temperature - resistance	down to -40°C	down to -30°C	down to -50°C	down to -25°C	down to -40°C	down to -80°C	down to -10°C
oil resistance	good	good	moderate	very good	good	extremely good	extremely good
price level	1	2.5	3	10	8 - 10	2	10 - 20

Material Temperature Ranges

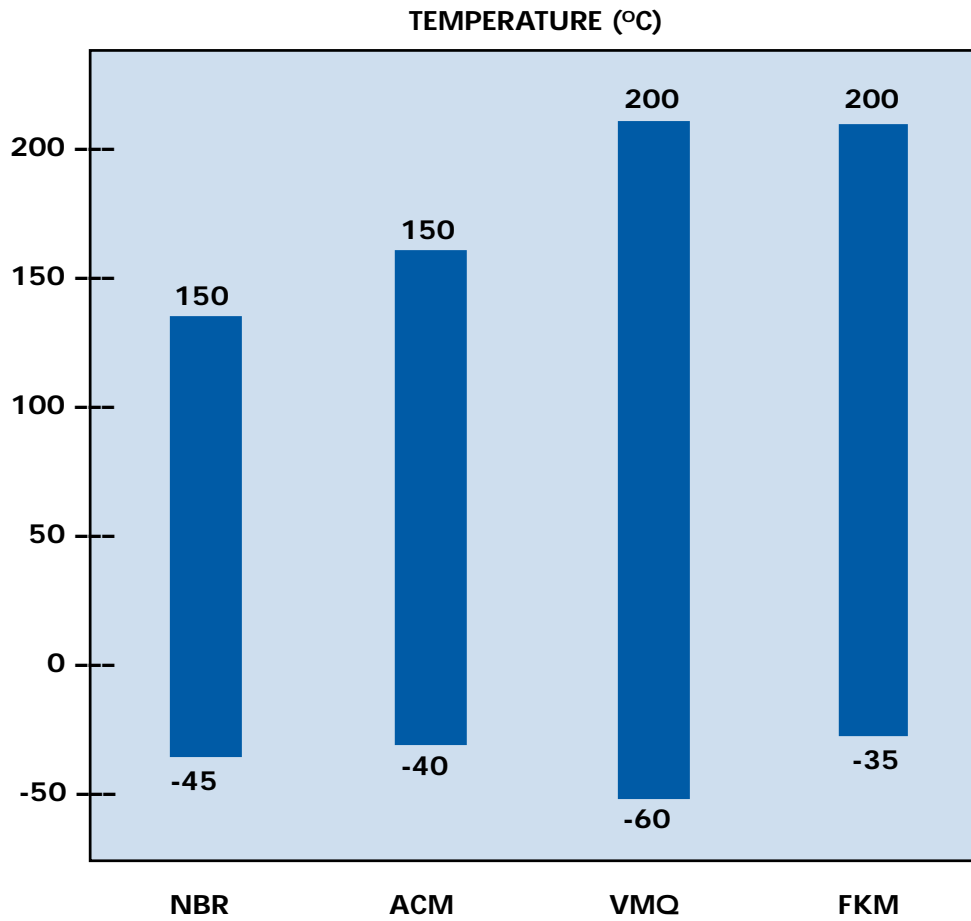

General Oil Seal Materials

NBR = NITRILE
ACM = POLYACRYLATE
VMQ = SILICONE
FKM = FLUOROELASTOMER

Material Hardness Changes

Elastomeric materials harden when exposed to high temperatures for an extended duration.

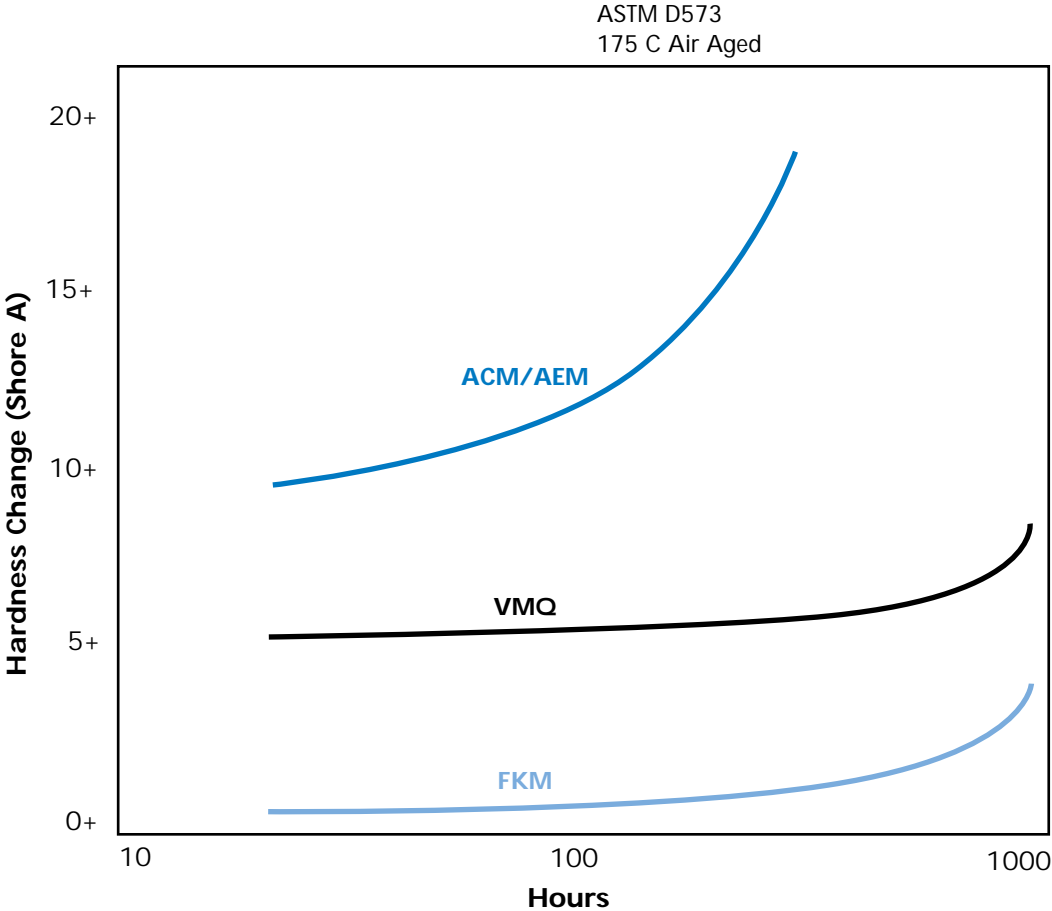

ACM = Polyacrylate
AEM = Ethylene Acrylic
VMQ = Silicone
FKM = Fluoroelastomer

Volume Changes

Material Volume Change

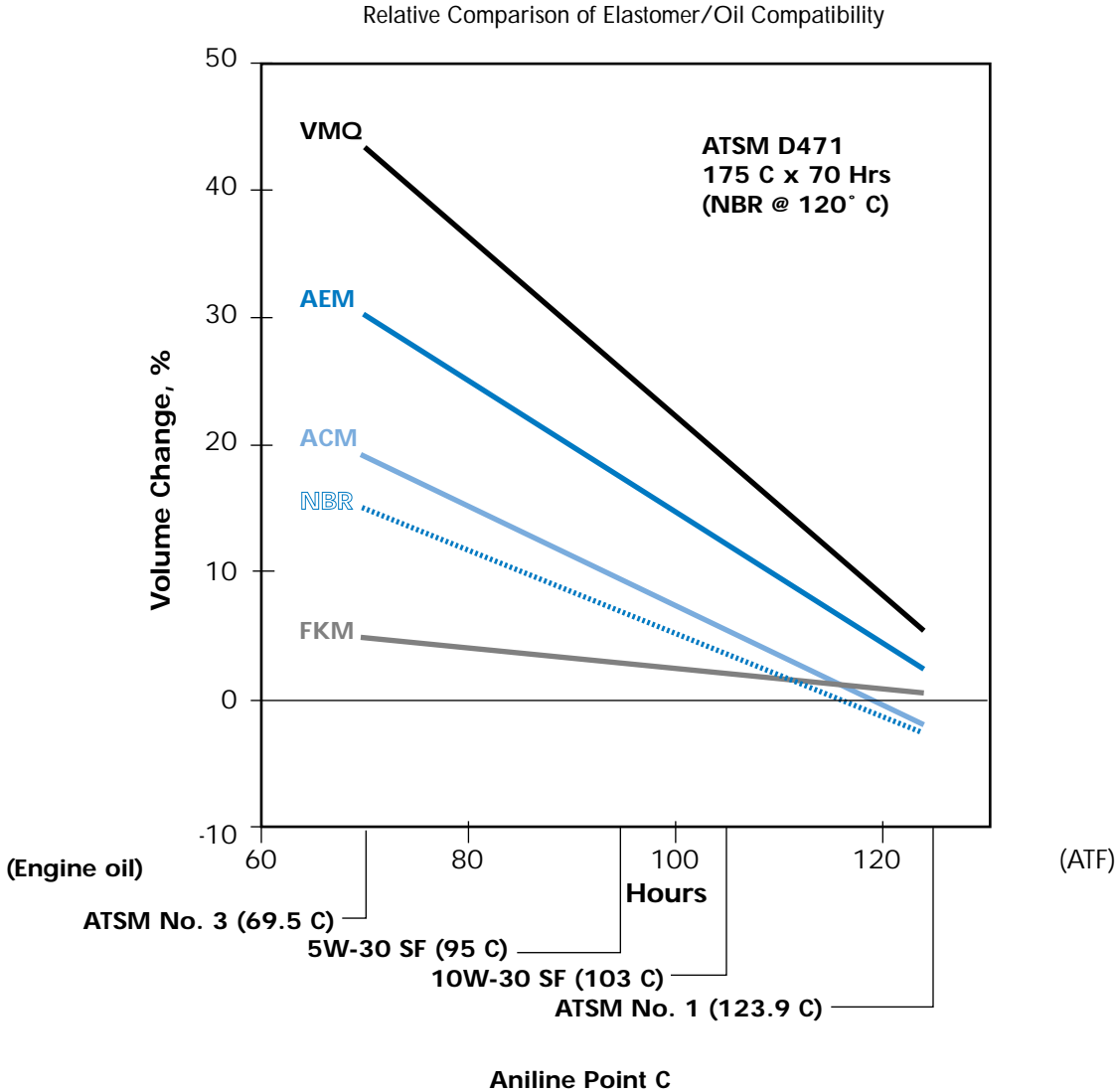

NOTE: The elastomer compound recipe and the additive package used in the lubricant both have a dramatic impact on the degree of elastomer deterioration.



Durability

Material Durability

Automotive Field Data - Engine Rear Seal Application
Different materials have different levels of wear resistance.

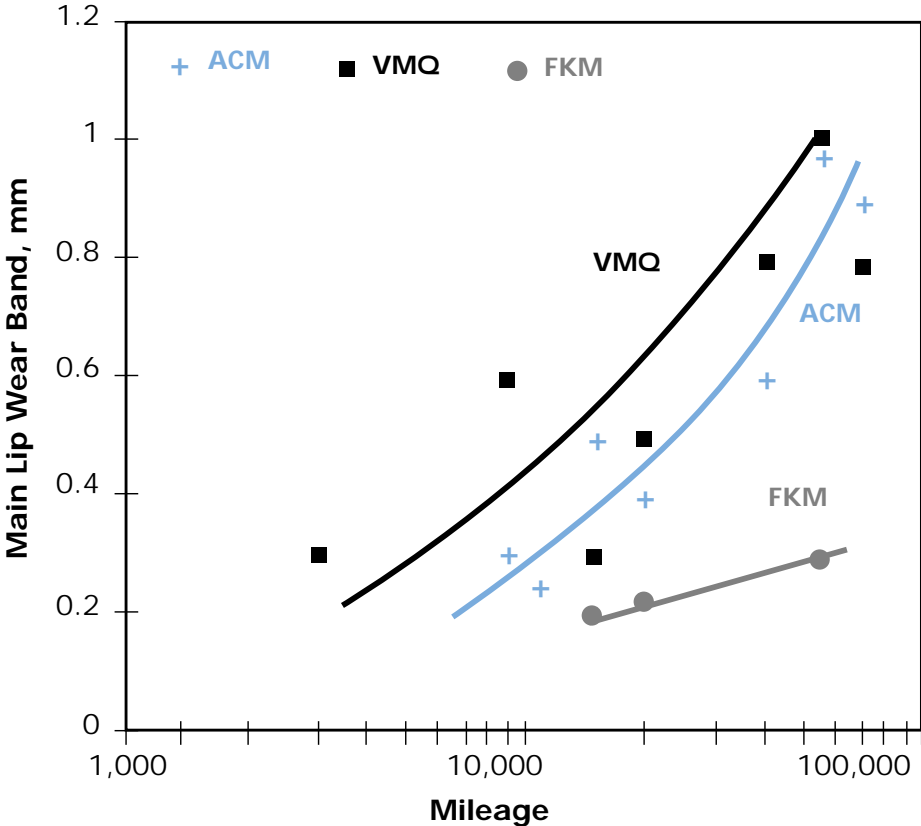

ATSM No. 1 (123.9 C)

ACM = Polyacrylate
VMQ = Silicone
FKM = Fluoroelastomer

Retraction Results

Cold Temperature Retraction Results

While at low temperatures, rubber loses its elasticity. The TR10 value is used to estimate the low temperature limit of rotating oil seals.

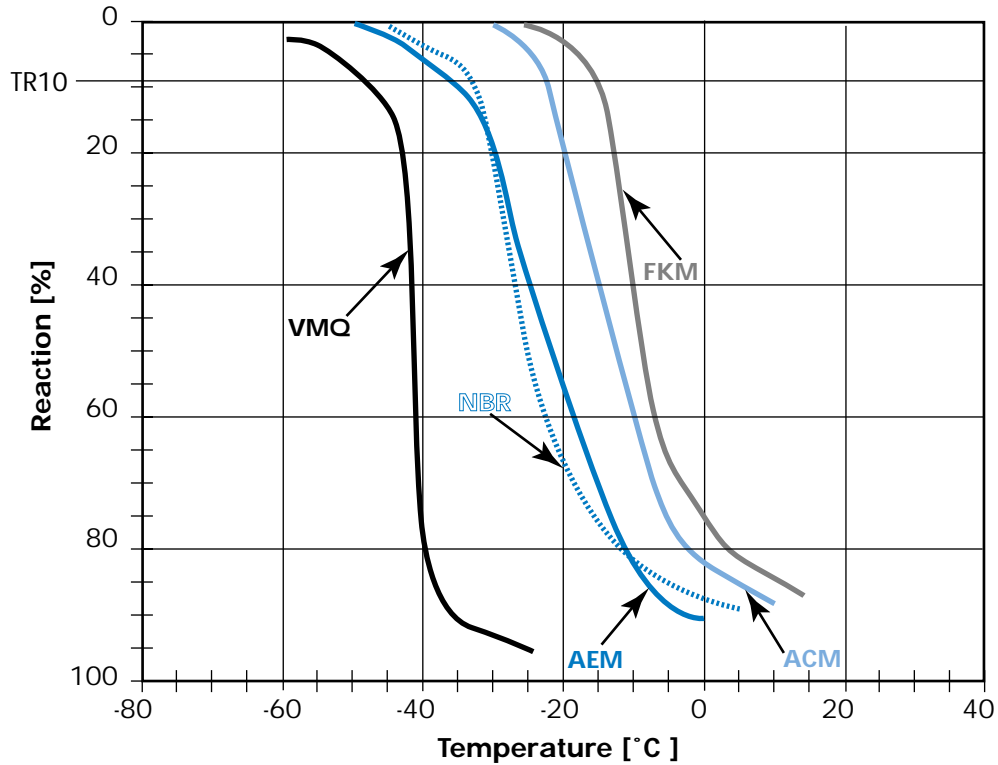

Oil Seal Material Typical TR10 Values

	NBR	NBR	NBR	ACM	AEM	VMQ	FKM
	LOW ACN	MID ACN	HI ACN				
TR10 °C	-45	-30	-15	-26	-30	-47	-17
TR10 °F	-49	-22	5	-15	-22	-53	1

Material Properties

1 = Little to no attack 2 = Weak to moderate attack 3 = Strong attack to complete destruction 4 = Please contact FNPG to ensure Warranty Avoidance

Medium	Temp.C	NBR	HNBR	ACM	VMO	FKM	PTFE	Medium	Temp.C	NBR	HNBR	ACM	VMO	FKM	PTFE
Accumulator acid (sulfuric acid)	60	3	3	4	4	1	1	Aqua regia	20	3	3	3	3	3	1
Acetaldehyde, with acetic acid, 90/10%	20	3	3	3	3	3	1	Arsenic acid, aqueous	60	1	1	4	4	1	1
Acetamide	20	4	4	4	4	4	1	Arsenic acid, aqueous	100	1	1	4	4	3	1
Acetic acid, aqueous, 25-60%	60	3	3	4	4	4	1	Asphalt	100	4	4	4	4	4	1
Acetic acid, dqueous, 85%	100	3	3	4	4	4	1	ASTM fuel A	60	1	1	2	3	1	1
Acetic acid, glacial	60	3	3	4	4	4	1	ASTM fuel B	60	2	2	3	3	1	1
Acetic anhydride	20	3	3	4	4	4	1	ASTM fuel C	60	3	3	3	3	1	1
Acetic anhydride	80	3	3	4	4	4	1	ASTM oil No.1	100	1	1	1	1	1	1
Acetone	20	3	3	3	3	3	1	ASTM oil No.2	100	1	1	1	1	1	1
Acetophenone	20	4	4	4	4	4	1	ASTM oil No.3	100	1	2	1	2	1	1
Acetylene	60	1	1	1	1	1	1	ATE brake fluid	100	3	3	3	1	3	1
Acrylic acid, Ethylester	20	3	3	3	3	3	1	ATF oil	100	1	1	3	2	1	1
Acrylonitril	60	3	3	4	3	3	1	Barium hydroxide, aqueous	60	1	1	4	4	1	1
Adipic acid, aqueous	20	1	1	4	4	1	1	Barium salts, aqueous	60	1	1	4	1	1	1
Aero-engine fuels JP3 (MIL-J 5624)	20	1	2	2	3	1	1	Beef tallow emulsion, sulphonated	20	1	1	4	2	1	1
Aero-engine fuels JP4 (MIL-J-5624)	20	1	2	2	3	1	1	Beer	20	1	1	1	1	1	1
Aero-engine fuels JP5 (MIL-J-5624)	20	1	2	2	3	1	1	Benzaldehyde, aqueous	60	3	3	4	4	1	1
Aero-engine fuels JP6 (MIL-J-25656)	20	1	2	2	3	1	1	Benzene	20	3	3	3	3	2	1
Air, oil-containing	80	1	1	1	1	1	1	Benzic acid, aqueous	60	1	1	4	1	1	1
Air, pure	80	1	1	1	1	1	1	Benzyl alcohol	60	4	4	4	2	4	1
Allyl alcohol	80	2	2	4	4	3	1	Bisulphite lye	50	2	2	4	4	4	1
Alum, aqueous	60	3	3	4	4	1	1	Bitumen	60	3	3	4	4	1	1
Alum, aqueous	100	1	1	1	1	1	1	Black lye	100	2	2	4	4	1	1
Aluminum sulphate, aqueous	60	1	1	4	4	1	1	Blast furnace gas	100	2	2	1	1	1	1
Aluminum sulphate, aqueous	100	1	1	4	4	3	1	Bleaching lye	60	3	3	4	4	2	1
Ammonia, 100%	20	2	2	4	4	3	1	Bone oil	60	1	1	1	2	1	1
Ammonia, aqueous	40	1	1	3	2	3	1	Borax, aqueous	60	1	1	4	1	1	1
Ammonium acetate, aqueous	60	1	1	4	4	3	1	Boric acid, aqueous	60	1	1	4	1	1	1
Ammonium carbonate	60	1	1	4	4	3	1	Brake fluids (glycolether)	80	3	3	3	1	4	1
Ammonium chloride, aqueous	60	1	1	4	4	1	1	Bromine water, saturated cold	20	3	3	4	4	4	1
Ammonium fluoride, aqueous	20	1	1	4	1	1	1	Bromine, liquid	20	3	3	4	4	4	1
Ammonium fluoride, aqueous	100	1	1	4	4	3	1	Bromine, vapor	20	3	3	4	4	4	1
Ammonium nitrate, aqueous	60	1	1	4	4	1	1	Bromobenzene	20	4	4	4	4	4	1
Ammonium nitrate, aqueous	100	1	1	4	4	1	1	Bunker oil	60	2	2	4	4	4	1
Ammonium phosphate, aqueous	60	1	1	4	4	3	1	Butadiene	60	4	4	4	2	1	1
Ammonium sulphatae	60	1	1	4	4	1	1	Butane, gaseous	20	1	1	1	4	1	1
Ammonium sulphate	100	1	1	4	4	3	1	Butanediol, aqueous	20	1	1	4	4	2	1
Ammonium sulphide, aqueous	60	1	1	4	4	1	1	Butanediol, aqueous	60	1	1	4	4	4	1
Ammonium sulphide, aqueous	100	2	2	4	4	3	1	Butanol, aqueous	20	1	2	2	1	2	1
Amyl acetate	20	3	3	4	4	3	1	Butanol, aqueous	60	3	3	4	4	4	1
Amyl alcohol	60	2	2	4	4	3	1	Butter	20	1	1	4	1	1	1
Aniline	60	3	3	4	3	3	1	Butter	80	1	1	4	4	1	1
Aniline hydrochloride	20	2	2	4	2	1	1	Butylacetate	20	3	3	4	4	3	1
Aniline hydrochloride	100	3	3	4	4	4	1	Butyl alcohol	60	3	3	4	4	4	1
Anisole	20	3	3	4	4	4	1	Butyl phenol	20	3	3	3	3	2	1
Anthraquinone sulphonic acid, aqueous	30	2	2	4	4	4	1	Butylene glycol	60	1	1	4	1	2	1
Antifreeze (motor vehicle)	60	1	1	4	1	1	1	Butylene, liquid	20	1	1	4	4	1	1
Antimony chloride, aqueous	20	1	1	1	1	1	1	Butyne diol	20	1	1	4	4	2	1
Antimony trichloride, anhydrous	60	1	1	4	4	4	1	Butyraldehyde	20	4	4	4	4	4	1

1 = Little to no attack 2 = Weak to moderate attack 3 = Strong attack to complete destruction 4 = Please contact FNPG to ensure Warranty Avoidance

Medium	Temp.C	NBR	HNBR	ACM	VMQ	FKM	PTFE	Medium	Temp.C	NBR	HNBR	ACM	VMQ	FKM	PTFE
Butyric acid, aqueous	20	1	1	4	4	1	1	Cyclohexane	20	1	1	2	2	1	1
Calcium bisulphite, aqueous	20	1	1	4	4	1	1	Cyclohexanol	20	1	1	4	4	4	1
Calcium chloride, aqueous	100	1	1	4	1	1	1	cyclohexanone	20	3	3	4	4	4	1
Calcium hydroxide, aqueous	20	1	1	4	1	1	1	Cyclohexylamine	20	3	3	4	4	3	1
Calcium hypochlorite, aqueous	60	3	3	3	4	2	1	Decahydronaphthalene (Decalin)	20	3	3	2	4	2	1
Calcium nitrate, aqueous	40	1	1	4	1	1	1	Decahydronaphthalene (Decalin)	60	3	3	2	4	2	1
Calcium phosphate, aqueous	20	1	1	4	1	1	1	Desmodur T	20	3	3	3	4	4	1
Camphor	20	1	1	4	4	2	1	Desmophen 2000	80	1	1	4	4	4	1
Camphorated oil	20	1	2	4	4	2	1	Detergent, synthetic	60	1	1	3	4	1	1
Carbolinuem	80	3	3	3	3	1	1	Detergents	100	1	1	4	4	2	1
Carbolinuem	60	4	4	4	4	4	1	Dextrin, aqueous	60	1	1	4	1	1	1
Carbon dioxide, dry	60	1	1	1	1	1	1	Diacetone alcohol	20	2	2	4	4	4	1
Carbon disulphide	20	3	3	4	3	1	1	Dibenzyl ether	20	3	3	4	4	3	1
Carbon monoxide, dry	60	1	1	1	1	1	1	Dibutyl ether	20	3	3	4	4	3	1
Carbon monoxide, moist	20	1	1	1	1	1	1	Dibutyl phthalate	20	3	3	4	1	1	1
Carbon tetrachloride	60	3	3	4	4	1	1	Dibutyl phthalate	60	3	3	4	1	2	1
Caustic potash, 50%	60	2	2	3	3	3	1	Dibutyl sebacate	60	3	3	4	2	4	1
Caustic soda	20	2	2	3	3	3	1	Dichloroacetic acid	60	3	3	4	4	3	1
Cellosolve	20	4	4	4	4	4	1	Dichlorethane	20	3	3	3	3	2	1
Chloral hydrate, aqueous	60	3	3	4	4	2	1	Dichlorethylene	20	3	3	4	4	2	1
Chloamine, aqueous	20	1	1	4	4	4	1	Dichlorobenzene	20	3	3	4	4	1	1
Chlorethanol	60	3	3	4	4	3	1	Dichlorobutylene	20	3	3	4	4	2	1
Chloric acid, aqueous	80	3	3	4	4	2	1	Dichloromethane	20	3	3	3	3	1	1
Chloride of lime, aqueous	60	3	3	4	4	1	1	Diesel fuel	60	1	2	2	2	1	1
Chlorine water, saturated	20	3	3	4	4	1	1	Diethyl ether	20	3	3	4	4	3	1
Chlorine, dry gaseous	20	3	3	4	4	2	1	Diethyl sebacate	20	3	3	4	4	2	1
Chlorine, liquid	20	3	3	4	4	2	1	Diethylamine	20	2	2	4	4	3	1
chlorine, moist gaseous	20	3	3	4	4	2	1	Diethylene glycol	20	1	1	4	1	1	1
Chlorobenzene	20	3	3	3	3	2	1	Diglycolic acid, aqueous	60	2	2	4	4	1	1
Chlorobromomethane	20	4	4	4	4	2	1	Dihexyl phthalate	60	3	3	4	4	3	1
Chloroform	20	3	3	4	4	2	1	Diisobutyl ketone	60	3	3	4	4	3	1
Chlorsulphonic acid	20	3	3	3	3	4	1	Dimethyl ether	20	3	3	4	4	3	1
Chromic acid, gaseous	60	3	3	4	4	1	1	Dimethylamine	20	3	3	4	4	3	1
Chromic acid, aqueous	60	3	3	4	4	1	1	Dimethylformamide	60	3	3	4	3	3	1
Chromic acid/sulphuric acid/water 50/15/35%	40	3	3	4	4	1	1	Dinonyl phthalate	30	3	3	4	4	3	1
Citric acid, aqueous	60	1	1	4	4	1	1	Dioctyl phthalate	60	3	3	4	4	3	1
Clophen T 64	100	3	3	4	2	1	1	Diethyl sebacate	60	3	3	4	4	3	1
Clophen-A types	100	3	3	4	1	1	1	Dioxane	60	3	3	4	4	3	1
Coconut fat	80	1	1	1	1	1	1	Dipentene	20	2	2	4	4	1	1
Coconut fatty alcohol	20	1	1	4	4	1	1	Diphenyl	20	3	3	4	4	1	1
Coconut oil	60	1	1	1	1	1	1	Diphenyl oxide	100	4	4	4	4	4	1
Coconut oil	80	1	1	4	4	1	1	Engine oils	100	1	1	1	2	1	1
Cod-liver oil	20	1	1	1	1	1	1	Epichlorhydrin	20	4	4	4	4	3	1
Coking-oven gas	80	3	3	4	4	1	1	Essential Oils	20	3	3	4	4	2	1
Copper fluoride, aqueous	50	1	1	4	4	1	1	Ethane	20	1	1	1	2	1	1
Copper nitrate, aqueous	60	1	1	4	4	1	1	Ethanol	20	1	1	4	1	4	1
Copper sulphate, aqueous	60	1	1	4	4	1	1	Ethanol	80	3	3	4	4	3	1
copper (1) chloride, aqueous	20	1	1	1	1	1	1	Ethanol w/ acetic acid (fermentation mixture)	20	3	3	4	4	3	1
Cottonseed oil	20	1	1	4	4	1	1	Ethanol w/ acetic acid (fermentation mixture)	60	3	3	4	4	3	1
Cresol, aqueous	45	3	3	4	4	1	1	Ethyl acetate	60	3	3	4	1	3	1
Crotonaldehyde	20	4	4	4	4	3	1	Ethyl acrylate	20	3	3	3	3	3	1



1 = Little to no attack 2 = Weak to moderate attack 3 = Strong attack to complete destruction 4 = Please contact FNPG to ensure Warranty Avoidance

Medium	Temp.C	NBR	HNBR	ACM	VMQ	FKM	PTFE	Medium	Temp.C	NBR	HNBR	ACM	VMQ	FKM	PTFE
Ethyl benzene	20	3	3	3	3	2	1	Hexane	60	1	1	1	3	1	1
Ethyl chloride	20	2	2	3	3	2	1	Hexane triol	20	1	1	4	1	1	1
Ethyl ether	20	3	3	3	3	3	1	Hexene	20	2	2	1	4	1	1
Ethylene chloride	20	2	2	3	3	2	1	Hydraulic fluids, hydraulic oils	80	1	1	1	2	1	1
Ethylene diamine	60	3	3	3	3	3	1	Hydraulic fluids, oil-in-water emulsions HFA	55	1	1	4	4	1	1
Ethylene glycol	100	1	1	4	2	1	1	Hydraulic fluids, phosphoric acid ester HFD	80	3	3	3	3	4	1
Ethylene trichloride	20	4	4	4	4	4	1	Hydraulic fluids, polyglycol-water emulsions	60	1	1	4	1	1	1
Exhaust gasses,containing carbon dioxide	60	1	1	1	1	1	1	Hydraulic fluids, water-in oil emulsions HFB	60	4	4	4	4	1	1
Exhaust gases, containing carbon monoxide	60	1	1	1	1	1	1	Hydrazine hydrate	20	2	2	4	4	4	1
Exhaust gases, containing hydrogen chloride	60	2	2	4	4	1	1	Hydrobromic acid, aqueous	60	2	2	4	4	4	1
Exhaust gases,containing hydrogen fluoride, traces	60	1	1	4	4	1	1	Hydrochloric acid, concentrated	80	3	3	4	4	1	1
Exhaust gases, containing nitrous gases, traces	60	4	4	3	3	1	1	Hydrochloric acid, concentrated	20	3	3	4	4	1	1
Exhaust gases, containing nitrous gases, traces	80	4	4	3	3	1	1	Hydrochloric acid, dilute	20	1	2	4	4	1	1
Exhaust gases, containing sulphur dioxide	60	2	2	4	4	1	1	Hydrofluoric acid, concentrated	20	4	4	4	4	4	1
Exhaust gases, containing sulphuric acid	60	2	2	4	4	1	1	Hydrogen	20	1	1	1	1	1	1
Exhaust gases, containing sulphuric acid	80	3	3	4	4	1	1	Hydrogen chloride gas	60		3	34	4	1	1
Fats: mineral, animal or vegetable	80	1	1	1	1	1	1	Hydrogen peroxide, aqueous	20	3	3	4	2	1	1
Fatty acids	100	2	2	4	4	1	1	Hydrogen sulphide, aqueous	60	2	2	4	4	1	1
Fatty alcohol	20	1	1	1	1	1	1	Hydrogen sulphide, dry	60	2	2	4	4	1	1
Fertilizer salt, aqueous	60	1	1	4	1	1	1	Hydroquinone, acqueous	20	1	1	2	4	1	1
Fish oil	20	1	1	1	1	1	1	Hydrosulphite, aqueous	40	2	2	4	4	4	1
Fluorine, dry	60	3	3	4	4	4	1	Hydroxylamine sulphate, aqueous	35	1	1	4	1	4	1
Fluorobenzene	20	3	3	3	3	2	1	Ink	20	1	2	1	1	2	1
Fluorocarbon oils	100	4	4	4	1	4	1	Iodine, tincture	20	1	1	4	2	1	1
Fluorosilicic acid	100	4	4	4	4	4	1	Iodoform	20	4	4	4	4	1	1
Fluorosilicic acid, aqueous	60	1	1	4	4	1	1	Iron (III) chloride, aqueous	40	1	1	4	4	1	1
Formaldehyde, aqueous	60	2	2	3	4	4	1	Isobutanol	20	2	2	3	1	1	1
Formamide	60	3	3	4	4	2	1	Isoctane	20	1	1	1	2	1	1
Formic acid, aqueous	60	3	3	4	4	4	1	Isophorone	20	4	4	4	4	4	1
Freon according...								Isopropanol	60	2	2	3	1	2	1
Fruit juice	100	2	2	4	1	1	1	Isopropyl acetate	80	3	3	3	3	3	1
Furane	20	4	4	4	4	3	1	Isopropyl chloride	20	3	3	3	3	1	1
Furfural	20	3	3	4	4	4	1	Isopropyl ether	60	3	3	3	3	3	1
Furfuryl alcohol	20	4	4	4	4	4	1	Kerosene	20	1	2	1	2	1	1
Furnace gas, dry	60	3	3	4	1	1	1	Lactam	80	3	3	4	4	3	1
Gas liquor	40	1	1	3	3	1	1	Lactic acid, aqueous	40	1	1	4	4	1	1
Gas oil	80	1	1	1	2	1	1	Lanolin (wool fat)	60	1	1	1	1	1	1
Gasohol	20	3	3	3	3	4	1	Laughing gas (nitrous oxide)	20	1	1	1	1	1	1
Gelatine, aqueous	40	1	1	2	1	1	1	Lauryl alcohol	20	1	1	4	4	1	1
Glaubers salt, aqueous (sodium sulphate)	20	1	1	2	4	1	1	Lavender oil	20	2	2	2	4	1	1
Glucose, aqueous	80	1	1	4	1	1	1	Lead acetate, aqueous	60	1	2	4	4	1	1
Glue	20	1	1	1	1	1	1	Lead acetate, aqueous	100	1	2	4	4	3	1
Glycerol chlorhydrin	60	3	3	4	4	4	1	Lead nitrate, aqueous	20	1	1	4	4	1	1
Glycerol, aqueous	100	1	1	4	1	1	1	Lemon juice, undiluted	20	1	1	4	1	4	1
Glycine, aqueous, 10%	40	2	2	4	4	1	1	Linoleic acid	20	2	2	4	2	2	1
Glycol, aqueous	100	1	1	4	2	2	1	Linseed oil	60	1	1	1	1	1	1
Glycolic acid, aqueous, 37%	20	1	1	4	1	1	1	Liquers	20	1	1	1	1	1	1
Grape sugar, aqueous	80	1	1	4	1	1	1	Lithium bromide, aqueous		1	1	4	1	1	1
Heating oil, mineral-oil based	60	1	1	1	2	1	1	Lithium chloride, aqueous	20	1	1	1	1	1	1
Henkel P3 solution	100	1	1	4	4	4	1	Machine oil, mineral	80	1	1	1	2	1	1
Heptane	60	1	1	1	3	1	1	Magnesium chloride, aqueous	100	1	1	3	4	1	1
Hexachlorobutadiene	20	3	3	4	4	1	1	Magnesium sulphate, aqueous	100	1	1	3	4	1	1
Hexachlorobutadiene	20	4	4	4	4	1	1	Maize oil (corn oil)	60	1	1	4	4	1	1
Hhexaldehyde	20	3	3	4	4	4	1	Maleic acid, aqueous	100	1	1	4	4	1	1

1 = Little to no attack 2 = Weak to moderate attack 3 = Strong attack to complete destruction 4 = Please contact FNPG to ensure Warranty Avoidance

Medium	Temp.C	NBR	HNBR	ACM	VMQ	FKM	PTFE	Medium	Temp.C	NBR	HNBR	ACM	VMQ	FKM	PTFE
Maleic anhydride	60	4	4	4	4	1	1	Nitrous gases (oxides of nitrogen)	20	3	3	3	3	1	1
Margarine	80	1	1	1	1	1	1	o-Nitrotoluene	60	3	3	3	3	3	1
Marsh gas (methane)	20	1	1	1	1	1	1	Octane	20	4	4	4	4	1	1
Menthol	60	3	3	4	4	2	1	Octyl alcohol	20	2	2	4	2	1	1
Mercury	60	1	1	1	1	1	1	Octyl cresol	20	4	4	3	3	2	1
Mercury salts, aqueous	60	1	1	4	1	1	1	Oil, crude	20	1	2	1	2	1	1
Mesityl oxide	4	4	4	4	4	1		Oleum, 10%	20	3	3	3	3	1	1
Methane	20	1	1	1	1	1	1	Oleyl alcohol	20	1	1	1	1	1	1
Methanol	60	2	2	4	1	4	1	Olive oil	60	1	1	1	1	1	1
Methoxy butanol	60	1	1	4	4	1	1	Oxalic acid, aqueous	100	3	3	4	4	1	1
Methyl acrylate	20	3	3	3	3	3	1	Ozone	20	4	2	2	1	1	1
Methyl bromide	20	3	3	3	3	1	1	Palm kernel fatty acid	60	1	1	4	4	1	1
Methyl chloride	20	3	3	4	4	2	1	Palmitic acid	60	2	2	4	4	1	1
Methyl ethyl ketone	20	3	3	3	3	3	1	Paraffin	60	1	1	4	4	1	1
Methyl isobutyl ketone	20	3	3	3	3	3	1	Paraffin emulsions	40	1	1	1	1	1	1
Methyl methacrylate	20	3	3	3	3	3	1	Paraffin oil	60	1	1	1	1	1	1
Methylamine, aqueous	20	3	3	4	4	3	1	Pectin	20	1	1	1	1	1	1
Methylene chloride	20	3	3	3	3	1	1	Pentachlorodiphenyl	60	3	3	4	4	4	1
Milk	20	1	1	4	1	1	1	Pentane	20	1	1	4	4	1	1
Milk of lime	80	3	3	4	4	1	1	Peracetic acid <1%	40	3	3	3	3	1	1
Mineral oil	100	1	1	1	2	1	1	Peracetic acid <10%	40	3	3	3	3	4	1
Mineral water	60	1	1	4	1	1	1	Perchloroethylene	60	3	3	4	3	1	1
Mixed acid I (sulphuric acid/nitric acid/water)	20	3	3	3	3	1	1	Perchloric acid	100	3	3	4	4	1	1
Mixed acid II (sulphuric acid/phosphoric acid/water)	40	3	3	4	4	1	1	Petrol	60	1	2	1	3	1	1
Molasses	100	1	1	4	4	1	1	Petrol/benzene mixture, 50/50%	20	3	3	3	3	1	1
Monobromobenzene	20	3	3	3	3	2	1	Petrol/benzene mixture, 60/40%	20	3	3	3	3	1	1
Monochloroacetic acid	60	2	2	4	4	4	1	Petrol/benzene mixture, 70/30%	20	2	3	2	3	1	1
Monochloroacetic acid, ethyl ester	60	3	3	3	3	2	1	Petrol/benzene mixture, 80/20%	20	2	3	2	3	1	1
Monochloroacetic acid, methyl ester	60	3	3	3	3	2	1	Petrol/benzene/ethanol, 50/30/20%	20	3	3	3	3	2	1
Morpholine	60	3	3	4	4	4	1	Petroleum	60	1	1	1	2	1	1
Myristyl alcohol	20	1	1	1	1	1	1	Petroleum ether	60	1	2	1	2	1	1
n-Propanol	60	2	2	4	1	2	1	Phenol, aqueous, up to 90%	80	3	3	4	4	2	1
Naftolen ZD	20	2	2	4	4	1	1	Phynyl benzene	20	3	3	4	4	2	1
Naphtha	20	3	3	2	4	1	1	Phenyl ethyl ether	20	3	3	3	3	3	1
Naphthalene	60	3	3	4	4	1	1	Phenyl hydrazine	60	2	2	4	4	2	1
Naphthoic acid	20	2	2	4	4	1	1	Phenylhydrazine chlorhydrate, aqueous	80	2	2	4	4	2	1
Natural gas	20	1	1	4	1	1	1	Phosgene	20	4	4	4	4	4	1
Natural gas, crude	20	1	1	1	1	1	1	Phosphien	20	3	3	4	4	2	1
Nickel acetate, aqueous	20	1	1	4	4	4	1	Phosphoric acid, aqueous	60	3	3	4	4	1	1
Nickel chloride, aqueous	20	1	1	4	4	1	1	Phosphorus oxychloride	20	3	3	4	4	4	1
Nickel sulphate, aqueous	60	1	1	4	4	1	1	Phosphorus trichloride	20	3	3	4	4	2	1
Nitric acid, dilute	80	2	2	4	2	1	1	Photographic developer	40	1	1	4	4	1	1
Nitric acid, fuming	60	3	3	4	4	3	1	Photographic emulsions	20	1	1	4	4	1	1
Nitric, concentrated	80	3	3	4	4	3	1	Photographic fixing baths	40	1	1	1	1	1	1
Nitrobenzene	60	3	3	3	3	1	1	Phthalic acid, aqueous	60	1	1	4	4	1	1
Nitrogen	20	1	1	1	1	1	1	Pickling solution (leather)	20	4	4	4	4	2	1
Nitrogen dioxide	20	4	4	4	3	4	1	Picric acid	20	2	2	4	4	1	1
Nitroglycerine	20	3	3	4	4	1	1	Picric acid, aqueous	20	1	1	4	1	1	1
Nigroglycol, aqueous	20	3	3	4	4	1	1	Pine needle oil	20	2	2	4	4	1	1
Nitromethane	20	3	3	3	3	3	1	Pine needle oil	60	2	2	1	2	1	1
Nitropropene	20	3	3	3	3	3	1	Pinene	20	2	2	4	4	1	1



1 = Little to no attack 2 = Weak to moderate attack 3 = Strong attack to complete destruction 4 = Please contact FNPG to ensure Warranty Avoidance

Medium	Temp.C	NBR	HNBR	ACM	VMQ	FKM	PTFE	Medium	Temp.C	NBR	HNBR	ACM	VMQ	FKM	PTFE
Piperidine	4	4	4	4	4	4	1	Sodium thiosulphate	60	3	3	4	4	1	1
Potash, aqueous	40	1	1	4	1	1	1	Spermaceti	20	1	1	4	4	1	1
Potassium acetate, aqueous	20	1	2	4	4	1	1	Spindle oil	60	1	1	1	1	1	1
Potassium bisulphate, aqueous	40	1	1	4	4	1	1	Starch syrup	60	1	1	4	4	1	1
Potassium borate, aqueous	60	1	1	4	4	1	1	Starch aqueous	60	1	1	1	1	1	1
Potassium bromate, 10%	60	1	2	4	4	1	1	Steam	130	3	3	4	3	4	1
Potassium bromide, aqueous	60	1	1	4	4	1	1	Stearic acid	60	1	1	1	1	1	1
Potassium carbonate, aqueous	40	1	1	4	1	1	1	Stoddard solvent	20	1	1	1	4	1	1
Potassium chlorate, aqueous	60	3	3	4	4	1	1	Styrene	20	3	3	4	3	2	1
Potassium chloride, aqueous	60	1	1	4	4	1	1	Succinic acid, aqueous	60	1	1	4	4	1	1
Potassium chromate, aqueous	20	2	2	4	4	1	1	Sugar syrup	60	1	1	4	4	1	1
Potassium cyanide, aqueous	40	1	1	4	1	1	1	Sulphur	60	4	4	4	4	1	1
Potassium cyanide, aqueous	80	2	2	4	1	1	1	Sulphur chloride	20	3	3	4	4	1	1
Potassium dichromate, aqueous 40%	20	2	2	4	4	1	1	Sulphur dioxide, aqueous	60	3	3	4	4	1	1
Potassium iodide, aqueous	60	1	1	4	4	1	1	Sulphur dioxide, dry	80	3	3	4	4	1	1
Potassium nitrate, aqueous	60	1	1	4	4	1	1	Sulphur dioxide, liquid	60	3	3	4	4	1	1
Potassium perchlorate, aqueous	80	3	3	4	4	1	1	Sulphur hexafluoride	20	1	1	1	1	1	1
Potassium permanganate, aqueous	40	3	3	4	4	1	1	Sulphuric acid, concentrated	50	3	3	4	3	1	1
Potassium persulphate, aqueous	60	3	3	4	4	1	1	Sulphuric acid, dilute	20	2	2	4	4	1	1
Potassium sulphate, aqueous	60	1	1	4	4	1	1	sulphuryl chloride	20	3	3	4	4	1	1
Propane, liquid gaseous	20	1	1	1	1	1	1	Tallow	60	1	1	4	4	1	1
Propargyl alcohol, aqueous	60	1	1	4	4	1	1	Tannic acid	60	1	1	2	1	1	1
Propionic acid, aqueous	60	1	1	4	4	1	1	Tannin	40	2	2	4	4	1	1
Propylene glycol	60	1	1	4	4	1	1	Tanning extract	20	1	1	2	1	1	1
Propylene oxide	20	3	3	4	4	4	1	Tar	20	3	3	4	4	4	1
Prussic acid (hydrocyanic acid)	20	4	4	4	1	4	1	Tar oil	20	3	3	4	4	4	1
Pyridine	20	3	3	3	3	3	1	Tartaric acid, aqueous	60	1	1	4	1	1	1
Pyrrole	20	4	4	4	2	4	1	Test media ASTM oil No.1	100	1	1	1	1	1	1
Rapeseed oil	20	2	2	2	4	1	1	Test media ASTM oil No. 2	100	1	1	1	2	1	1
Refrigerant								Test media ASTM oil No. 3	100	1	2	1	3	1	1
Sagrotan	20	2	2	4	1	1	1	Tetrachlorethane	60	3	3	4	4	2	1
Salicylic acid	20	1	1	4	4	1	1	Tetrachlorethylene	60	3	3	4	4	2	1
Salt water	20	1	1	4	4	1	1	Tetraethyl lead	20	2	2	4	4	1	1
Sea water	20	1	1	4	1	1	1	Tetrahydrofuran	20	3	3	4	4	3	1
Silicic acid, aqueous	60	1	1	4	4	1	1	Tetrahydronaphthalene (tetralin)	20	3	3	4	4	1	1
Silicone grease	20	1	1	1	3	1	1	Thionyl chloride	20	3	3	4	4	1	1
Silicone oil	20	1	1	1	1	1	1	Thiophene	60	3	3	4	4	3	1
Silver nitrate, aqueous	100	2	2	4	4	1	1	Tin (II) chloride, aqueous	80	1	1	4	4	1	1
Silver salts, aqueous	60	2	2	4	1	1	1	Titanium tetrachloride	20	1	1	2	2	2	1
skydrol	20	3	3	3	3	3	1	Toluene	20	3	3	3	3	2	1
Soap solution, aqueous	20	1	1	4	4	1	1	Town gas, benzene free	20	1	1	1	1	1	1
Soda, aqueous	60	2	2	4	1	1	1	Transformer oil	60	1	2	1	2	1	1
Sodium benzoate, aqueous	40	1	1	4	4	1	1	Transmission fluid, Type A	20	1	1	1	2	1	1
Sodium bicarbonate, aqueous	60	1	1	4	4	1	1	Triacetin	20	2	2	4	4	4	1
Sodium bisulphite, aqueous	100	1	1	4	4	1	1	Tributoxyethyl phosphate	20	3	3	4	4	2	1
Sodium chlorate	20	3	3	4	4	1	1	Tributyl phosphate	60	3	3	4	4	2	1
Sodium chloride	100	1	1	4	4	1	1	Trichloroacetic acid, aqueous	60	2	2	4	4	3	1
Sodium hypochlorite, aqueous	20	2	2	4	4	1	1	Trichlorethyl phosphage	20	3	3	4	4	3	1
Sodium nitrate, aqueous	60	1	1	4	4	1	1	Trichlorethylene	20	3	3	4	3	2	1
Sodium nitrite	60	2	2	4	4	1	1	Tricresyl phosphate	60	3	3	4	4	2	1
Sodium phosphate, aqueous	60	1	1	4	4	1	1	Triethanolamine	20	3	3	4	4	4	1
Sodium silicate, aqueous	60	1	1	4	4	1	1	Triethyl aluminum	20	4	4	4	4	2	1
Sodium sulphate, aqueous	60	1	1	4	4	1	1	Triethyl borane	20	4	4	4	4	1	1
Sodium sulphide	40	1	1	4	4	1	1	Triglycoll	20	1	1	4	4	1	1

1 = Little to no attack 2 = Weak to moderate attack 3 = Strong attack to complete destruction 4 = Please contact FNPG to ensure Warranty Avoidance

Medium	Temp.C	NBR	HNBR	ACM	VMQ	FKM	PTFE	Medium	Temp.C	NBR	HNBR	ACM	VMQ	FKM	PTFE
Trimethylol propane, aqueous	100	3	3	4	4	1	1	Whisky	20	1	1	4	1	1	1
Trinitrotoluene	20	4	4	4	4	2	1	White lye	100	2	2	4	4	3	1
Trioctyl phosphate	60	3	3	4	4	2	1	White oil	20	1	1	1	1	1	1
Trisodium phosphage	20	1	1	4	1	1	1	White spirit	60	1	2	1	4	1	1
Turpentine	60	2	2	4	4	1	1	Wine	20	1	1	4	1	1	1
Turpentine, oil of	20	2	2	4	4	1	1	Xylamon (wood perservatives)	20	3	3	3	4	2	1
Urea, aqueous	60	1	1	4	4	1	1	Xylene	20	3	3	3	3	2	1
Vaseline	60	1	1	1	2	1	1	yeast, aqueous	20	1	1	4	1	1	1
Vaseline oil	60	1	1	1	2	1	1	Zeolites	20	1	1	1	1	1	1
Vinyl acetate	20	4	4	4	4	4	1	Zinc acetate	20	2	2	1	1	1	1
Vinyl chloride, liquid	20	4	4	4	4	4	1								
Water	100	1	1	3	2	1	1								
Wax alcohol	60	1	2	4	4	1	1								

Radial Shaft Seal Styles

Simrit style designations...Simrit Europe

BA Rubber covered-spring loaded
 B1 Metal O.D.-spring loaded
 B2 Double metal case-spring loaded
 D Flex section
 D1 Profile to standard
 DRL Left handed helix
 DRR Right handed helix
 DRW Bi-directional helix
 F Ready molded lip
 FG Protected spring
 HD High pressure
 J Sealing lip on O.D.
 L Low friction seal
 LD Profile Seal
 SD Silicone profile
 SL Ready molded dust lip
 U Universal profile
 UD Triangle profile
 X1 O.D. specifications
 X2 Sealing lip specifications
 X3 Ready molded helix
 X4 Dust lip inside sealing lip
 X7 Grooved O.D.

BL With metal part
 OB Without metal part
 NIBL Stainless steel metal part
 MSBL Brass metal part
 ALUBL Aluminum metal part
 OF Without spring
 NIF Stainless steel spring
 BRF Bronze spring
 STF Steel spring
 SF Special Feature

Simrit style designations...NOK

S Spring loaded single lip
 T Auxiliary Lip(s) spring loaded main lip
 V Non-spring loaded single lip
 K Auxiliary lip and non-spring loaded main lip
 D Double lip, both spring loaded
 A Assembled seal - metal O.D.
 B Metal O.D. (non-assembled)
 C Rubber covered O.D.
 M Combination assembled seal
 3 Auxiliary lip directed toward main lip
 4 Two stepped main lip
 6 Three stepped main lip
 9 Side lip
 L Reciprocal special outward dust lip
 V Medium pressure main lip
 2 Rubber bond area minimized with Metal O.D.
 5 Flange
 J PTFE lip member
 K Non-woven fabric lip
 1 Lip reinforcing retainer for single lip seal
 N High pressure double lip seal with lip retainer
 H Hydrodynamic aid to main lip (Helix)



Glossary of Terms

Assembled spring – Inside Diameter:

The inner diameter of the garter spring, with the ends securely joined.

Axial clearance: The gap between the toe face to the head section and the inside surface of the inner case.

Circumferential surface roughness:

Surface roughness of a shaft measured in a direction (plane) normal to the centerline axis.

Cocked assembly: An installation in which the plane of the outside seal face is not perpendicular to the shaft axis.

Coil: One turn of the coiled wire garter spring.

Contact approach angle: Synonym: Angle, Outside lip

Contact line: The line of intersection between the outside and inside lip surfaces of a radial shaft seal. In a cross-section view, this intersection is illustrated as a point.

Contact line height: The axial distance from the outside seal face to the lip contact line.

Contact width: The width of the lip contact area of a radial shaft seal, measured in the axial direction.

Crack: A sharp break or fissure in the sealing element.

Cut: A deep discontinuity in the seal material whereby no material is removed.

Deformation: A stress induced change of form or shape.

Dynamic Run-out: Twice the distance the center of the shaft is displaced from the center of rotation and expressed in TIR. That Run-out to which the seal lip is subjected due to the outside diameter of the shaft not rotating in a true circle.
Synonym: Shaft Run-out

Elastomer: An elastic rubber like substance.

Extrusion: Permanent displacement of part of a seal into a gap, under the action of fluid pressure.

Fluid side: The side of the seal which in normal use faces toward the fluid being sealed.

Functional lip diameter: The apparent inner diameter of the seal when the seal case is concentric with the outer diameter of the sizing mandrel in an air gage, light box, or similar inspection equipment.

Garter spring: A helically coiled wire with its' ends connected to form a ring. It is used in tension for maintaining a radial sealing force between element of a radial lip seal and a shaft.

Heel: Synonym: Heel section

Heel section: The portion of a lip seal which is attached to the seal case and bounded by the flex section and the outside face.

Helix contact width: The axial width of that portion of the contact surface of a helix seal which is formed by the helical ribs. It is equal to the total axial width of the contact surface minus the width of the static lip.

Housing bore: A cylindrical surface which mates with the outside diameter of the outer seal case.

Hydrodynamic seal: A dynamic sealing device which utilizes the viscous shear and inertia forces of the fluid; imparted by a helically grooved or ribbed seal lip, to generate a pressure differential that opposes fluid flow.

Inclusion: Foreign matter included in the seal material.

Inner case: A rigid, cup-shaped component of a seal assembly, which is placed inside the outer seal case. It has one or more of the following functions: reinforcing member, shield, spring retainer, lip-clamping device.

Inside face: That surface of the inner case which faces, and is usually in contact with, the fluid being sealed.

Inside single lip angle: The angle between the inside lip surface and the axis of the seal case.

Lip diameter: The inner diameter of the seal lip, measured with the spring installed.

Lip force: The radial force exerted by an extension spring and/or lip of a seal on the mating shaft. Lip force is expressed as force per unit of shaft circumference.

Lip height: The axial distance from the outside seal face to the toe face.

Lip ID to ID eccentricity: See: Radial Wall Variance

Lip opening pressure: The pressure necessary for flowing air at 10000 cc/min. between the contact surface of a radial lip seal and shaft-size mandrel under the following conditions: the seal case outer diameter clamped to be concentric with the mandrel and the pressurized air applied to the outside lip surface.

Lip seal: An elastomeric seal which prevents leakage in dynamic and static applications by reason of controlled interference between the seal lip and the mating surface.

Lubricant starvation: Lack of proper lubrication at the seal interface which may cause premature wear and early failure.

Offset: The radial distance between the axis of the seal bore and axis of shaft rotation.

Oil seal: A seal designed primarily for the retention of oil.

Outer case: the outer thin-wall rigid structure of the lip seal assembly which contains the inner case, the primary seal ring, the spring and the secondary seal.

Outside lip angle: The angle between the outside lip and the axis of the seal case.

Plunge ground: The surface texture of shaft or wear sleeve produced by presenting the grinding wheel perpendicular to the rotating shaft without axial motion.

Primary lip: The normally flexible elastomeric component of a shaft seal assembly, which rides against the rotating surface and affects the seal.

Radial lip seal: A type of seal which features a flexible sealing member referred to as a lip. The lip is usually an elastomeric material. It exerts radial sealing pressure on a mating shaft in order to retain fluids and/or exclude foreign matter.

Radial load: The total force (load) acting on the seal lip which tends to maintain contact of the lip on the shaft. It is the sum of the forces developed from seal interference and the garter spring.

Radial wall variation: the difference between the minimum and the maximum radial wall dimensions when measured around 360 degrees, of the seal lip.

Rib: A long, narrow projection which is normally triangular in cross-section and which is molded into the outside lip surface of a helical seal. It is oriented at an angle to the shaft axis. One end of the rib forms part of the seal-lip contact surface.

Rough trim: A trimmed surface with irregularities on the outside and inside lip surfaces in the immediate vicinity of the contact line

Roughness: Irregularities in shaft surface texture which result from the production process. (See SAE J448a [June, 1963].)

Scratch: A shallow discontinuity in the seal material whereby no material is removed.

Seal assembly: A group of parts, which includes sealing surfaces, provisions for initial loading, and a secondary sealing mechanism which accommodates the radial movement necessary for installation and operation.

Seal case: A rigid member to which the seal lip is attached.

Seal outer diameter: The external diameter of a lip-seal assembly.

Shaft eccentricity: The radial distance in which the geometric center of a shaft is displaced from the axis of shaft rotation.

Shaft lead: Spiral grooves on a shaft surface caused by relative axial movement of grinding wheel to shaft.

Shaft Run-out: See: Dynamic Run-out

Shaft surface finish: See: Shaft Surface Texture

Shaft surface texture: A term used to describe the quality, appearance or characteristics of the shaft surface resulting from operations, such as grinding, polishing, burnishing, etc. (See SAE J448a [June, 1963]).

Slip stick: A friction related phenomena in which the sealing element tends to adhere and rotate with the shaft surface momentarily until the elastic characteristics of the sealing element overcome the adhesive force, causing the seal lip to lose connection with the rotating shaft long enough to allow leakage. This cycle repeats itself continuously and is normally associated with non-lubricated and boundary-lubricated conditions

Spiral trim: A trimmed surface which has a spiral pattern.

Spring groove: A depression formed in the head section of the seal. It is generally semicircular in form and serves to accommodate and locate the garter spring.

Spring outside coil diameter: The outer diameter of an individual helical coil of a garter spring.

Spring retaining lip: The portion of the primary lip that restricts the axial movement of the extension spring from a predetermined position.

Trim: The removal of superfluous parts from a molded product, usually removal of parting line flash or feed spews.

Trim cut: Damage to the elastomeric portion of the seal during trimming.

Trimming angle: The angle between the trimmed face of a seal lip and the seal axis.

Trimmed lip diameter: The lip diameter in the free state (no spring) developed by knife trimming the molded portion of the sealing element to form the contact line.

Unbonded flash: Flash which does not adhere to the mating material.

Unirotational seal: A seal, designed for applications having a single direction of shaft rotation.

Unitized seal: A seal assembly in which all components necessary for accomplishing the complete sealing function are retained in a single package.

Under-cure: A degree of cure less than desired.

Volume swell: Increase in physical size caused by the swelling action of a liquid, generally expressed as a percent of the original volume.

Wear sleeve: A replacement metal ring generally used in assemblies to eliminate expensive shaft replacement caused by grooving that may occur at the seal-shaft interface.

Weepage: A minute amount of liquid leakage by a seal.

Conversion Charts

Fraction - mm

Fraction	Decimal	0	1	2	3	4	5	6	7	8	9	10
0			25.400	50.800	76.200	101.600	127.000	152.400	177.800	203.200	228.600	254.000
1/64	0.016	0.397	25.797	51.197	76.597	101.997	127.397	152.797	178.197	203.597	228.997	254.397
1/32	0.031	0.794	26.194	51.594	76.994	102.394	127.794	153.194	178.594	203.994	229.394	254.794
3/64	0.047	1.191	26.591	51.991	77.391	102.791	128.191	153.591	178.991	204.391	229.791	255.191
1/16	0.063	1.588	26.988	52.388	77.788	103.188	128.588	153.988	179.388	204.788	230.188	255.588
5/64	0.078	1.984	27.384	52.784	78.184	103.584	128.984	154.384	179.784	205.184	230.584	255.984
3/32	0.094	2.381	27.781	53.181	78.581	103.981	129.381	154.781	180.181	205.581	230.981	256.381
7/64	0.109	2.778	28.178	53.578	78.978	104.378	129.778	155.178	180.578	205.978	231.378	256.778
1/8	0.125	3.175	28.575	53.975	79.375	104.775	130.175	155.575	180.975	206.375	231.775	257.175
9/64	0.141	3.572	28.972	54.372	79.772	105.172	130.572	155.972	181.372	206.772	232.172	257.572
5/32	0.156	3.969	29.369	54.769	80.169	105.569	130.969	156.369	181.769	207.169	232.569	257.969
11/64	0.172	4.366	29.766	55.166	80.566	105.966	131.366	156.766	182.166	207.566	232.966	258.366
3/16	0.188	4.762	30.162	55.562	80.962	106.362	131.762	157.162	182.562	207.962	233.362	258.762
13/64	0.203	5.159	30.559	55.959	81.359	106.759	132.159	157.559	182.959	208.359	233.759	259.159
7/32	0.219	5.556	30.956	56.356	81.756	107.156	132.556	157.956	183.356	208.756	234.156	259.556
15/64	0.234	5.953	31.353	56.753	82.153	107.553	132.953	158.353	183.753	209.153	234.553	259.953
1/4	0.250	6.350	31.750	57.150	82.550	107.950	133.350	158.750	184.150	209.550	234.950	260.350
17/64	0.266	6.747	32.147	57.547	82.947	108.347	133.747	159.147	184.547	209.947	235.347	260.747
9/32	0.281	7.144	32.544	57.944	83.344	108.744	134.144	159.544	184.944	210.344	235.744	261.144
19/64	0.297	7.541	32.941	58.341	83.741	109.141	134.541	159.941	185.341	210.741	236.141	261.541
5/16	0.313	7.938	33.338	58.738	84.138	109.538	134.938	160.338	185.738	211.138	236.538	261.938
21/64	0.328	8.334	33.734	59.134	84.534	109.934	135.334	160.734	186.134	211.534	236.934	262.334
11/32	0.344	8.731	34.131	59.531	84.931	110.331	135.731	161.131	186.531	211.931	237.331	262.731
23/64	0.359	9.128	34.528	59.928	85.328	110.728	136.128	161.528	186.928	212.328	237.728	263.128
3/8	0.375	9.525	34.925	60.325	85.725	111.125	136.525	161.925	187.325	212.725	238.125	263.525
25/64	0.391	9.922	35.322	60.722	86.122	111.522	136.922	162.322	187.722	213.122	238.522	263.922
13/32	0.406	10.319	35.719	61.119	86.519	111.919	137.319	162.719	188.119	213.519	238.919	264.319
27/64	0.422	10.716	36.116	61.516	86.916	112.316	137.716	163.116	188.516	213.916	239.316	264.716
7/16	0.438	11.112	36.512	61.912	87.312	112.712	138.112	163.512	188.912	214.312	239.712	265.112
29/63	0.456	11.509	36.909	62.309	87.709	113.109	138.509	163.909	189.309	214.709	240.109	265.509
15/32	0.469	11.906	37.306	62.706	88.106	113.506	138.906	164.306	189.706	215.106	240.506	265.906
31/64	0.484	12.303	37.703	63.103	88.503	113.903	139.303	164.703	190.103	215.503	240.903	266.303
1/2	0.500	12.700	38.100	63.500	88.900	114.300	139.700	165.100	190.500	215.900	241.300	266.700
33/64	0.516	13.097	38.497	63.897	89.297	114.697	140.097	165.497	190.897	216.297	241.697	267.097
17/32	0.531	13.494	38.894	64.294	89.694	115.094	140.494	165.894	191.294	216.694	242.094	267.494
35/64	0.547	13.891	39.291	64.691	90.091	115.491	140.891	166.291	191.691	217.091	242.491	267.891
9/16	0.563	14.288	39.688	65.088	90.488	115.888	141.288	166.688	192.088	217.488	242.888	268.288
37/64	0.578	14.684	40.084	65.484	90.884	116.284	141.684	167.084	192.484	217.884	243.284	268.684
19/32	0.594	15.081	40.481	65.881	91.281	116.681	142.081	167.481	192.881	218.281	243.681	269.081
39/64	0.609	15.478	40.878	66.278	91.678	117.078	142.478	167.878	193.278	218.678	244.078	269.478
5/8	0.625	15.875	41.275	66.675	92.075	117.475	142.875	168.275	193.675	219.075	244.475	269.875
41/64	0.641	16.272	41.672	67.072	92.472	117.872	143.272	168.672	194.072	219.472	244.872	270.272
21/32	0.656	16.669	42.069	67.469	92.869	118.269	143.669	169.069	194.469	219.869	245.269	270.669
43/64	0.672	17.066	42.466	67.866	93.266	118.666	144.066	169.466	194.866	220.266	245.666	271.066
11/16	0.688	17.462	42.862	68.262	93.662	119.062	144.462	169.862	195.262	220.662	246.062	271.462
45/64	0.703	17.859	43.259	68.659	94.059	119.459	144.859	170.259	195.659	221.059	246.459	271.859
23/32	0.719	18.256	43.656	69.056	94.456	119.856	145.256	170.656	196.056	221.456	246.856	272.256
47/64	0.731	18.653	44.053	69.453	94.853	120.253	145.653	171.053	196.453	221.853	247.253	272.653
3/4	0.750	19.050	44.450	69.850	95.250	120.650	146.050	171.450	196.850	222.250	247.650	273.050
49/64	0.766	19.447	44.847	70.247	95.647	121.047	146.447	171.847	197.247	222.647	248.047	273.447
25/32	0.781	19.844	45.244	70.644	96.044	121.444	146.844	172.244	197.644	223.044	248.444	273.844
51/64	0.797	20.241	45.641	71.041	96.441	121.841	147.241	172.641	198.041	223.441	248.841	274.241
13/16	0.813	20.638	46.038	71.438	96.838	122.238	147.638	173.038	198.438	223.838	249.238	274.638
53/64	0.828	21.034	46.434	71.834	97.234	122.634	148.034	173.434	198.834	224.234	249.634	275.034
27/32	0.844	21.431	46.831	72.231	97.631	123.031	148.431	173.831	199.231	224.631	250.031	275.431
55/64	0.859	21.828	47.228	72.628	98.028	123.428	148.828	174.228	199.628	225.028	250.428	275.828
7/8	0.875	22.225	47.625	73.025	98.425	123.825	149.225	174.625	200.025	225.425	250.825	276.225
57/64	0.891	22.622	48.022	73.422	98.822	124.222	149.622	175.022	200.422	225.822	251.222	276.622
29/32	0.906	23.019	48.419	73.819	99.219	124.619	150.019	175.419	200.819	226.219	251.619	277.019
59/64	0.922	23.416	48.816	74.216	99.616	125.016	150.416	175.816	201.216	226.616	252.016	277.416
15/16	0.938	23.812	49.212	74.612	100.012	125.412	150.812	176.212	199.628	227.012	252.412	277.812
61/64	0.935	24.209	49.609	75.009	100.409	125.809	151.209	176.609	200.009	227.409	252.809	278.209
31/32	0.969	24.606	50.006	75.406	100.806	126.206	151.606	177.006	202.406	227.806	253.206	278.606
63/64	0.984	25.003	50.403	75.803	101.203	126.603	152.003	177.403	202.803	228.203	253.603	279.003



Temperature

C	F or C	F	C	F or C	F	C	F or C	F	C	F or C	F	C	F or C	F	
-100 to 0															
-73.3	-100	-148.0	-62.2	-80	-112.0	-51.1	-60	-76.0	-40.0	-40	-40.0	-28.9	-20	-4.0	
-72.8	-99	-146.2	-61.7	-79	-110.2	-50.6	-59	-74.2	-39.4	-39	-38.2	-28.3	-19	-2.2	
-72.2	-98	-144.4	-61.1	-78	-108.4	-50.0	-58	-72.4	-38.9	-38	-36.4	-27.8	-18	-0.4	
-71.7	-97	-142.6	-60.6	-77	-106.6	-49.4	-57	-70.6	-38.3	-37	-34.6	-27.2	-17	1.4	
-71.1	-96	-140.8	-60.0	-76	-104.8	-48.9	-56	-68.8	-37.8	-36	-32.8	-26.7	-16	3.2	
-70.6	-95	-139.0	-59.4	-75	-103.0	-48.3	-55	-67.0	-37.2	-35	-31.0	-26.1	-15	5.0	
-70.0	-94	-137.2	-58.9	-74	-101.2	-47.8	-54	-65.2	-36.7	-34	-29.2	-25.6	-14	6.8	
-69.4	-96	-135.4	-58.3	-73	-99.4	-47.2	-53	-63.4	-36.1	-33	-27.4	-25.0	-13	8.6	
-68.9	-92	-133.6	-57.8	-72	-97.6	-46.7	-52	-61.6	-35.6	-32	-25.6	-24.4	-12	10.4	
-68.3	-91	-131.8	-57.2	-71	-95.8	-46.1	-51	-59.8	-35.0	-31	-23.8	-23.9	-11	12.2	
-67.8	-90	-130.0	-56.7	-70	-94.0	-45.6	-50	-58.0	-34.4	-30	-22.0	-23.3	-10	14.0	
-67.2	-89	-128.2	-56.1	-69	-92.2	-45.0	-49	-56.2	-33.9	-29	-20.2	-22.8	-9	15.8	
-66.7	-88	-126.4	-55.6	-68	-90.4	-44.4	-48	-54.4	-33.3	-28	-18.4	-22.2	-8	17.6	
-66.1	-87	-124.6	-55.0	-67	-88.6	-43.9	-47	-52.6	-32.8	-27	-16.6	-21.7	-7	19.4	
-65.6	-86	-122.8	-54.4	-66	-86.8	-43.3	-46	-50.8	-32.2	-26	-14.8	-21.1	-6	21.2	
-65.0	-85	-121.0	-53.9	-65	-85.0	-42.8	-45	-49.0	-31.7	-25	-13.0	-20.6	-5	23.0	
-64.4	-84	-119.2	-53.3	-64	-83.2	-42.2	-44	-47.2	-31.1	-24	-11.2	-20.0	-4	24.8	
-63.9	-83	-117.1	-52.8	-63	-81.4	-41.7	-43	-45.4	-30.6	-23	-9.4	-19.4	-3	26.6	
-63.3	-82	-115.6	-52.2	-62	-79.6	-41.1	-42	-43.6	-30.0	-22	-7.6	-18.9	-2	28.4	
-62.8	-81	-113.8	-51.7	-61	-77.8	-40.6	-41	-41.8	-29.4	-21	-5.8	-18.3	-1	30.2	
0 to 100															
-17.7	0	32.0	-6.6	20	68.0	4.4	40	104.0	15.6	60	140.0	26.7	80	176.0	
-17.2	1	33.8	-6.1	21	69.8	4.9	41	105.8	16.1	61	141.8	27.2	81	177.8	
-16.6	2	35.6	-5.5	22	71.6	5.5	42	107.6	16.6	62	143.6	27.8	82	179.6	
16.1	3	37.4	-5.0	23	73.4	6.0	43	109.4	17.2	63	145.4	28.3	83	181.4	
-15.5	4	39.2	-4.4	24	75.2	6.6	44	111.2	17.7	64	147.2	28.9	84	183.2	
-15.0	5	41.0	-3.9	25	77.0	7.1	45	113.0	18.3	65	149.0	29.4	85	185.0	
-14.4	6	42.8	-3.3	26	78.8	7.7	46	114.8	18.9	66	150.8	30.0	86	186.8	
-13.9	7	44.6	-2.8	27	80.6	8.2	47	116.6	19.4	67	152.6	30.5	87	188.6	
-13.3	8	46.4	-2.2	28	82.4	8.8	48	118.4	20.0	68	154.4	31.1	88	190.4	
-12.7	9	48.2	-1.6	29	84.2	9.4	49	120.2	20.5	69	156.2	31.6	89	192.2	
-12.2	10	50.0	-1.1	30	86.0	10.0	50	122.0	21.1	70	158.0	32.2	90	194.0	
-11.6	11	51.8	-0.6	31	87.8	10.5	51	123.8	21.6	71	159.8	32.7	91	195.8	
-11.1	12	53.6	0.0	32	89.6	11.1	52	125.6	22.2	72	161.6	33.3	92	197.6	
-10.5	13	55.4	0.5	33	91.4	11.4	53	127.4	22.7	73	163.4	33.8	93	199.4	
-10.0	14	57.2	1.1	34	93.2	12.2	54	129.2	23.3	74	165.2	34.4	94	201.2	
-9.4	15	59.0	1.6	35	95.0	12.7	55	131.0	23.9	75	167.0	35.0	95	203.0	
-8.8	16	60.8	2.2	36	96.8	13.3	56	132.8	24.4	75	168.8	35.5	96	204.8	
-8.3	17	62.6	2.7	37	98.6	13.9	57	134.6	25.0	77	170.6	36.1	97	206.8	
-7.7	18	64.4	3.3	38	100.4	14.4	58	136.4	25.5	78	172.4	36.6	98	208.4	
-7.2	19	66.2	3.8	39	102.2	15.0	59	138.2	26.1	79	174.2	37.2	99	210.2	
												37.7	100	212.0	
100 to 1000															
38.0	100	212.0	143.0	290	554.0	254.0	490	914.0	343.0	650	1202.0	454.0	850	1562.0	
43.0	110	230.0	149.0	300	572.0	260.0	500	932.0	349.0	660	1220.0	460.0	860	1580.0	
49.0	120	248.0	154.0	310	590.0	265.0	510	950.0	354.0	670	1238.0	465.0	870	1598.0	
54.0	130	266.0	160.0	320	608.0	271.0	520	968.0	360.0	680	1256.0	471.0	880	1616.0	
60.0	140	284.0	165.0	330	626.0	276.0	530	986.0	365.0	690	1274.0	476.0	890	1634.0	
65.0	150	302.0	171.0	340	644.0	282.0	540	1004.0	371.0	700	1292.0	482.0	900	1652.0	
71.0	160	320.0	177.0	350	662.0	288.0	550	1022.0	376.0	710	1310.0	487.0	910	1670.0	
76.0	170	338.0	182.0	360	680.0	293.0	560	1040.0	382.0	720	1328.0	493.0	920	1688.0	
83.0	180	356.0	188.0	370	698.0	299.0	570	1058.0	387.0	730	1346.0	498.0	930	1706.0	
88.0	190	374.0	193.0	380	716.0	304.0	580	1076.0	393.0	740	1364.0	504.0	940	1724.0	
93.0	200	392.0	199.0	390	734.0	310.0	590	1094.0	399.0	750	1382.0	510.0	950	1742.0	
99.0	210	410.0	204.0	400	752.0	315.0	600	1112.0	404.0	760	1400.0	515.0	960	1760.0	
100.0	212	413.0	210.0	410	770.0	321.0	610	1130.0	410.0	770	1418.0	520.0	970	1778.0	
104.0	220	428.0	215.0	420	788.0	326.0	620	1148.0	415.0	780	1436.0	526.0	980	1796.0	
110.0	230	446.0	221.0	430	806.0	332.0	630	1166.0	421.0	790	1454.0	532.0	990	1814.0	
115.0	240	464.0	226.0	440	824.0	338.0	640	1184.0	427.0	800	1472.0	538.0	1000	1832.0	
121.0	250	482.0	232.0	450	842.0										
127.0	260	500.0	238.0	460	860.0										
132.0	270	518.0	243.0	470	878.0										
138.0	280	536.0	249.0	480	896.0										

simrit®





Industrial & Consumer Business Unit

2250 Point Blvd., Suite 230
Elgin, IL 60123
Phone: 847.428.1261
Fax: 847.783.6519

North American Headquarters

47690 East Anchor Ct
Plymouth, MI 48170
Phone: 1.866.2SIMRIT
Fax: 734.354.5500

Aerospace & O-Ring Business Unit

25151 Arctic Ocean Drive
Lake Forest, CA 92630
Phone: 949.598.8155
Fax: 949.598.8151

Fluid Power Business Unit

3600 West Milwaukee
Spencer, IA 51301
Phone: 712.262.4867
Fax: 712.262.8160

www.simrit.com

1-866-2SIMRIT

